

Structure of microfiche

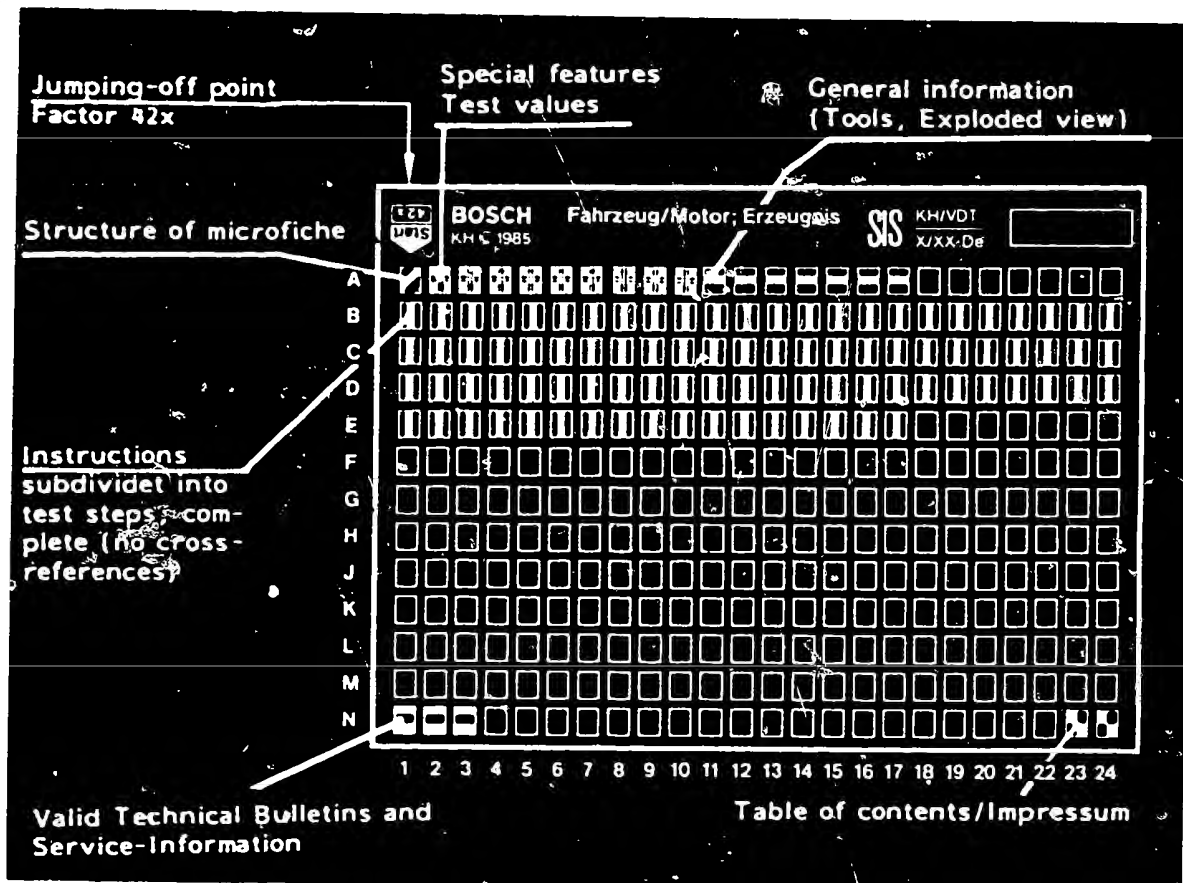

1. Read from left to right
2. Title of microfiche (appears on each coordinate)

E16	Product/component/test step
	Vehicle/engine

Coordinate

3. Limits of section



Beginning

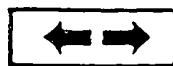

Mid-section



End



One-page section

4. References to relevant test steps in test specifications; coordinate e.g. C6

C6

A1	Trouble-shooting program	
-----------	--------------------------	--

1. SPECIAL FEATURES

These instructions describe the repair of injection pumps of series

PE(S).. MW.. S1 8 mm stroke
PE(S).. MW.. S100 10 mm stroke
PE(S).. MW.. S1500

without governor, manifold-pressure compensator and timing device.

The various models of governor are repaired in accordance with the respective repair instructions.

These instructions supersede:

W-413/100 - Ed. 1 + Suppl. 1, + Suppl. 2
I-413/100 ... 104

2. TEST SPECIFICATIONS

2.1 Leak test (suction gallery)
Test duration and test pressure
4 minutes at 5 bar
then
1 minute pulsating 0 - 5 bar

2.2 Leak test (camshaft chamber)
Test duration and test pressure
3 minutes at 1.5 bar
then
1 minute at 0.5 bar

2.3 Tightening torques

Screws, nuts etc are itemized on drawings on the following Coordinates A3...A8.

Below the drawings the items are repeated together with the Coordinates on which you can find the tightening torque.

A2

Test specifications

PE(S) .. MW .., 0 413 ..



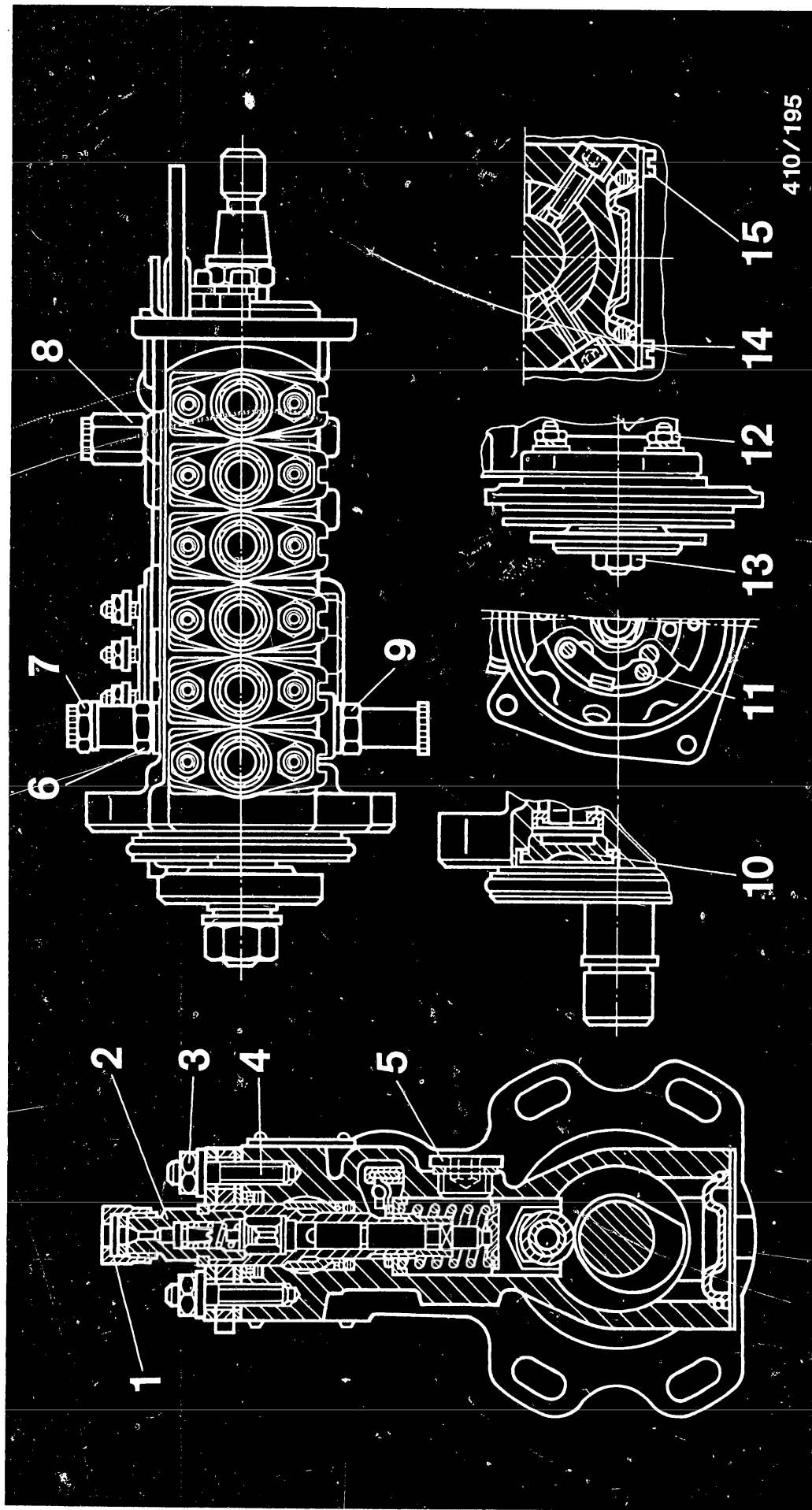

410/195

Item	Coordinate
1 ... 15	A 9

A3	Test specifications	↔
	PE(S) .. MW .., 0 413 ..	↔

A4	Test specifications	↔
	PE(S) .. MW .., 0 413 ..	↔

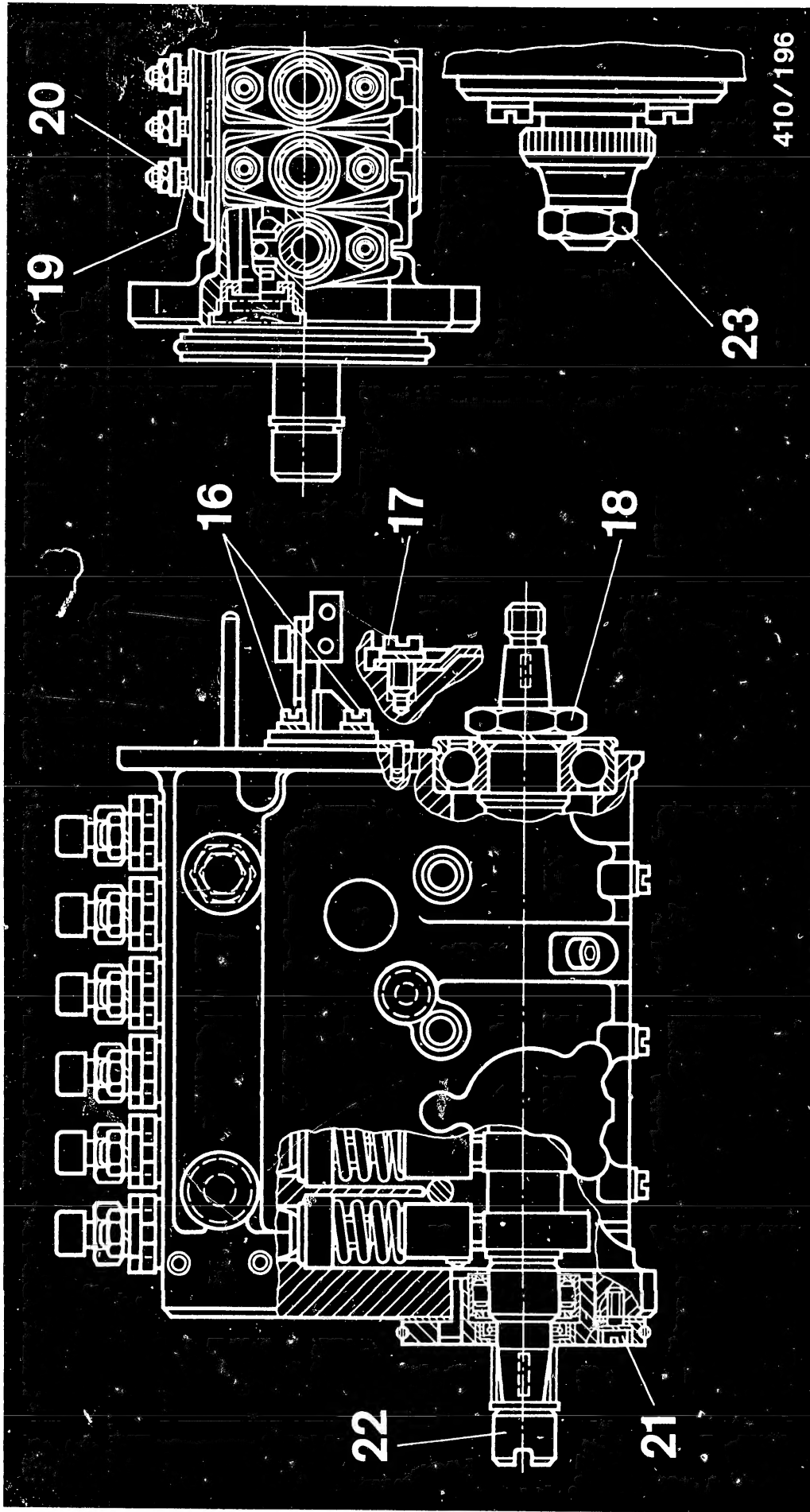

410/196

Item	Coordinate
16 ... 23	A 10

A6 Test specifications
PE(S) .. MW ... 0 413 ..

A5 Test specifications
PE(S) .. MW ... 0 413 ..



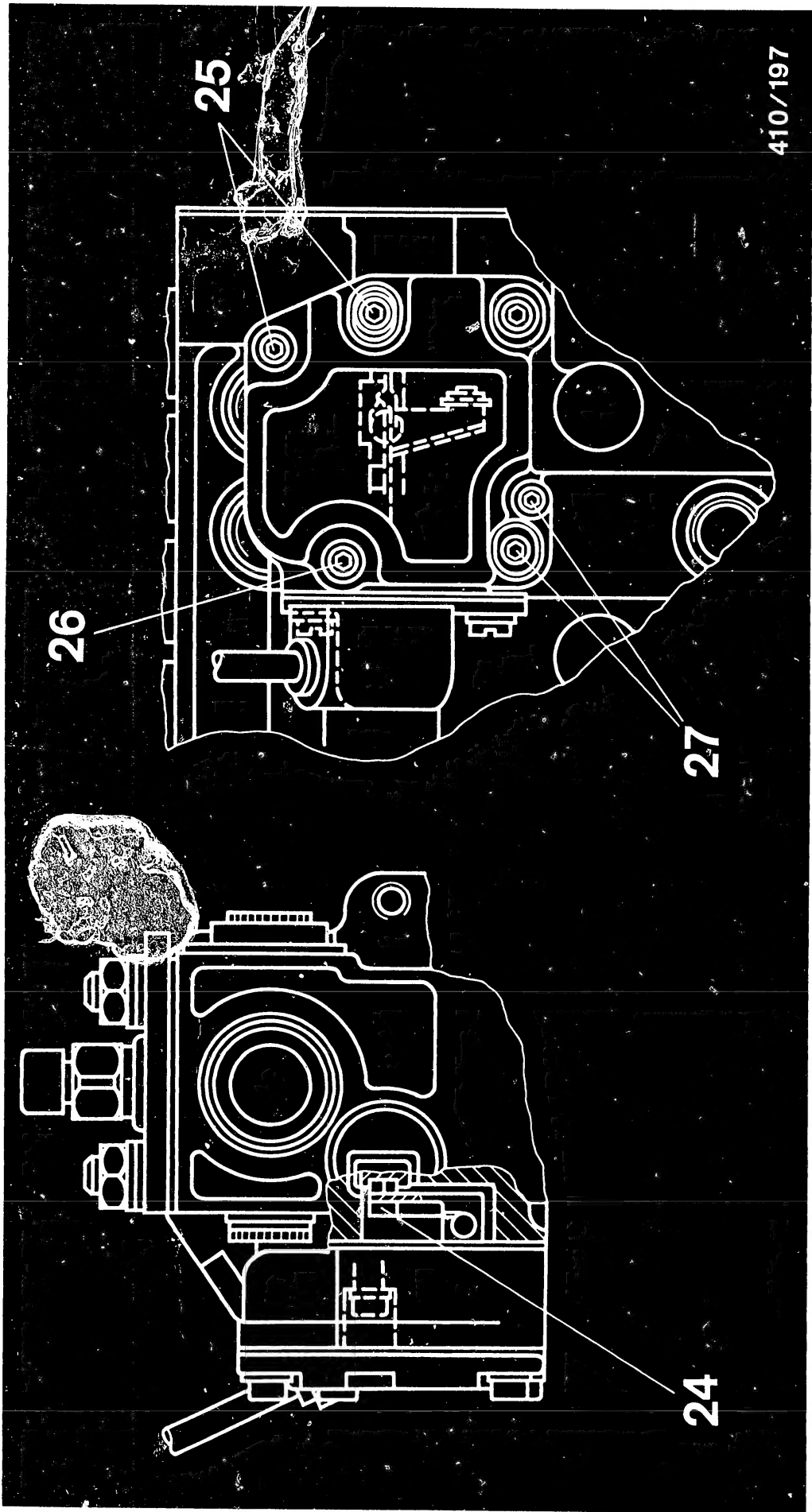

410/197

Item	Coordinate
24 ... 27	A 10

A7 Test specifications
PE(S) .. MW ... 0 413 ..

A8 Test specifications
PE(S) .. MW ... 0 413 ..



Tightening torques

Item No.	Description	Nm
1	Union nut	max. 25
2	Delivery-valve holder	50 - 60
3	Hexagon nut M 8	20 - 25
4	Threaded pin M 8	8 - 13
5	Screw plug	30 - 40
6	Overflow valve	30 - 40
7	Inlet-union screw	30 - 40
8	Fitting	30 - 40
9	Overflow valve	30 - 40
10	Control-rod screw plug M26x1.5	45 - 55
11	Flat-head screw	5 - 7
12	Hexagon screw/hexagon nut on IHC pumps	45 - 54 35 - 45
13	Hexagon nut	100 - 110
14	Hexagon-socket fillister-head screw for intermediate bearing Pre-tightening torque Final tightening torque	5 8 - 10
15	Base cover fastening screw	4 - 7

A9

Test specifications

PE(S) .. MW .., 0 413 ..



Tightening torques (continued)

Item No.	Description	Nm
16	Control-rod fastening screws	4 - 7
17	Fillister-head screw	4 - 7
18	Hexagon nut	100 - 120
19	Threaded pin M 6	3 - 4
20	Hexagon nut M 6	4 - 7
21	Bearing end plate fastening screws	
	Fillister-head screw M 6	7 - 9
	- Fillister-head Torx screw M 6 micro-encapsulated	12 - 15
	- Fillister head screw M 8	11 - 16
22	Timing device/coupling	85 - 100
23	Hexagon nut/drive pinion	60 - 70
24	Micro-encapsulated screw	2 - 3
25	Micro-encapsulated Torx fillister-head screw	3 - 4
26	Micro-encapsulated Torx fillister-head screw	3 - 4
27	Micro-encapsulated Torx fillister-head screw	3 - 4

A10

Test specifications

PE(S) .. MW .., 0 413 ..



3. GENERAL INFORMATION

- * Worn and damaged components must be discarded.
- * Sealing elements and camshaft bearings must always be replaced.
- * Injection-pump components which are stored for a lengthy period of time must be covered and protected against corrosion.

3.1 Lubrication instructions

Radial-lip-type oil seal	Lightly grease on circumference e.g. with Ftlv4-5700 002 ..
Plunger-and-barrel assys and delivery valves	Wash in cleaning agent; wet plunger with calibrating oil.
Seal rings	Rub with tallow.

3.2 To prevent possible skin rashes when immersing in the calibrating oil, grease hands with protective skin cream before leak test on suction gallery and camshaft chamber and wash with soap and water after test.



3.3. Cleaning the Components

Wash out components in low-inflammability, commercially available cleaning agent e.g. Chlorothene NU.

Then blow out with compressed air.

3.4 Safety Regulations When Handling Combustible Liquids

Decree on Working with Combustible Liquids (Vbf) issued by the Federal Ministry of Labor (BmA).

Safety Rules for Handling Chlorinated Hydrocarbons

for the Workshop

ZH 1/222

for the Employee

ZH 1/119

issued by the Central Association for German Employers' Liability Insurance Associations (Central Association for Accident Prevention and Industrial Medicine) Langwartweg 103, 5300 Bonn 5.

In countries outside the Federal Republic of Germany, observe the corresponding local regulations.

A12

General information

PE(S) .. MW .., 0 413 ..



4. TOOLS, FIXTURES, LUBRICANTS

Description	Part No.	Use
Clamping support	KDEP 2919	Clamping the injection pump
Support clamp	KDEP 2963	Clamping of pumps with end-flange mounting
Clamping parts	KDEP 1065	Clamping of pumps with cradle mounting
Clamping flange with reduction ring 85 mm diameter	1 685 720 017 1 680 202 005	For pumps with end-flange mounting - PES.. MW.. S1000 with 4-hole flange
Clamping flange	1 685 720 060	Pumps with end-flange mounting PES.. MW.. S1500 with large 4-hole flange (pilot dia. 95 mm)
Coupling half Cone 17 mm Cone 20 mm Cone 25 mm	1 416 430 012 1 416 430 017 1 416 430 022	Driving the injection pump
Mounting sleeve 17 mm diameter 20 mm diameter	KDEP 1054 KDEP 1055	Installing the camshaft
20 mm diameter 25 mm diameter	KDEP 2876 KDEP 2925 KDEP 2874	Protection of radial lip-type oil seal

A13

Tools, fixtures, lubricants

PE(S) .. MW .., 0 413 ..



Tools, fixtures, lubricants (continued)

Description	Part No.	Use
Tappet holder for 8 mm stroke + 10 mm stroke	KDEP 1051 KDEP 1068	Removal/ installation of roller tappets
Separation tube 2-tube 3-tube	KDEP 1052 KDEP 1053	Leak test on suction gallery
Spacer plate for pumps with 8 mm stroke	KDEP 1057	Spacer plate btwn. pump hsg. and barrel-and- valve assy
Puller	KDEP 1056	Removing/ pressing in capsule in mounting hole in pump hsg.
Press-in mandrel	KDEP 1058	Pressing the retainer into mounting hole
Press-in tool	KDEP 1059	Pressing in needle-roller bearing
Press-in tool	KDEP 1060	Pressing on/in camshaft bearing
Press-in tool	KDEP 1069	Pressing on/in camshaft bearing MW pump with 10 mm stroke



Tools, fixtures, lubricants (continued)

Description	Part No.	Use
Mounting device	KDEP 1066	Dismantling/ assembling barrel-and- valve assy
Clamping flange	1 685 720 018	For pumps with end-flange mounting - PES.. with 3- hole mounting
Press-in mandrel	KDEP 1590	Removing/ installing the control-rod mounting retainer
Press-in tool	KDEP 1592	Pressing in spacer ring
Mounting sleeve set	KDEP 1593	Assembly device for barrel-and- valve assy
Press-in sleeve	KDEP 1594	Pressing in radial-lip-type oil seal
Puller	KDEP 1131	Pulling off drive pinion
Forcing-off plate	KDEP 1580	Forcing off camshaft bearing
Puller	KDEP 2918	Pulling off drive coupling



Tools, fixtures, lubricants (continued)

Description	Part No.	Use
Assembly device	KDEP 1505 or KDEP 1050	Pressing down the roller tappets
Holding wrench Slot width 10 mm	KDEP 2906	
Holding wrench Slot width 12 mm	KDEP 2885	Holding the camshaft
Guide sleeve PE(S)..MW..	KDEP 1075	
Guide sleeve PE(S).. MW.. S1000 S1500	KDEP 1076	Pressing in the control-rod guide pin
Spacer plate for 10 mm stroke	KDEP 1591	Spacer plate between pump housing and barrel-and-valve assy

A16

Tools, fixtures, lubricants

PE(S) .. MW .., 0 413 ..



4.1 Lubricants

Description and designation	Container	Bosch Part No.
Mineral raffinate 9-10 E at 50° C		commercially available (e.g. BV Aral oil P 2736)
Diesel fuel		commercially available
Gasoline		commercially available
Lubricating oil SAE 90		commercially available
Sealant and adhesive Loctite CVX		commercially available
Beef tallow		comm. available
Loctite 601/638		comm. available
Leather oil mixture OL36V	1 can 0.5l	5 701 410 605
Special gear grease Ft v 27	Tube 50g Tube 250g	5 700 052 005 5 700 052 025
Hylomar sealant VS 98 44 - KK	Tube 25 g	5 927 350 002
Sealing paint, yellow KK 26 v 9	Tube 30 g	5 703 245 003

A17

Tools, fixtures, lubricants

PE(S) .. MW .., 0 413 ..



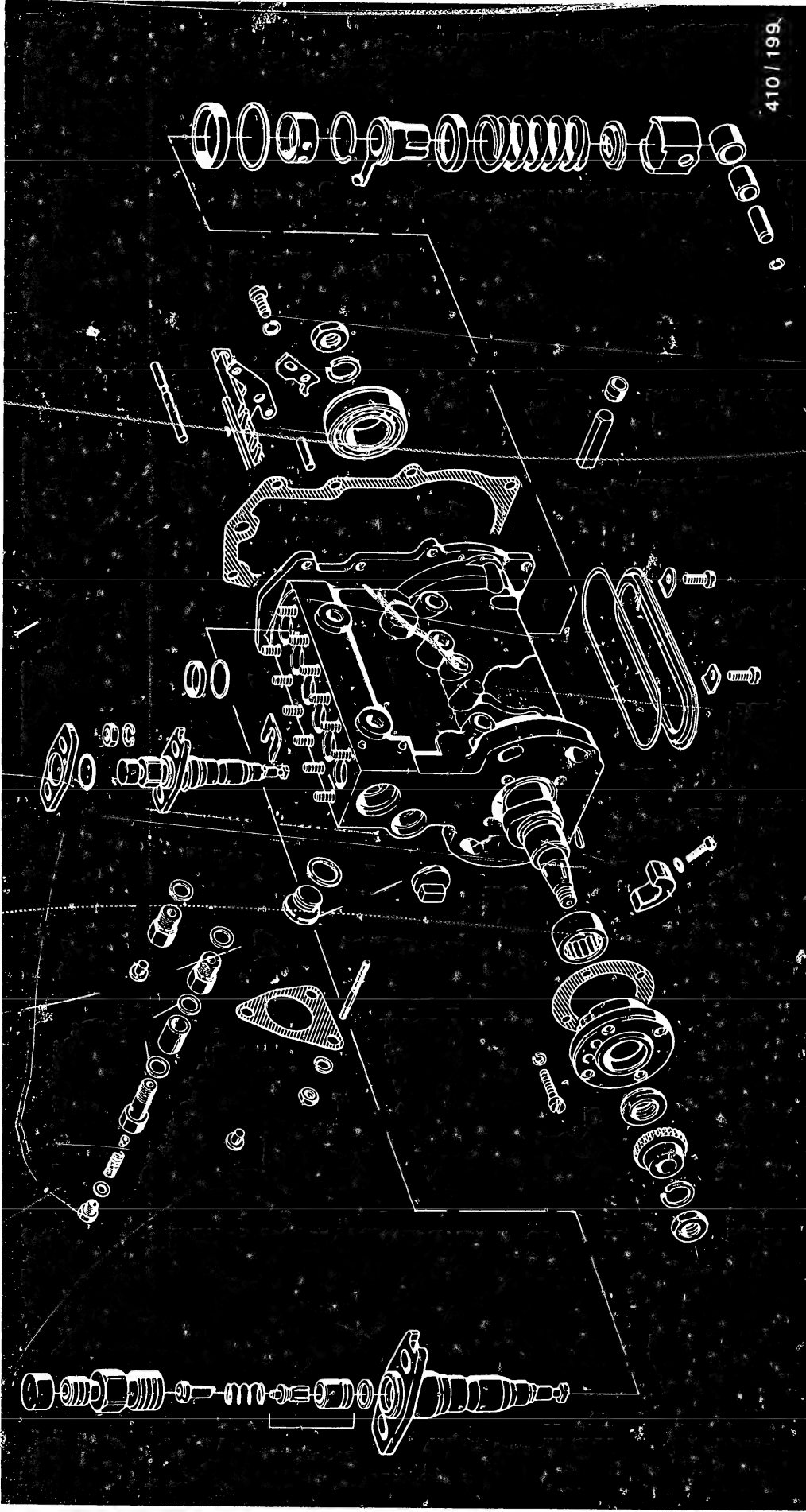

5. Exploded view PE(S) .. MW .. S 1000, .. S 1500

Special features:
with capsule and retainer on barrel-and-valve assembly.

A18	Exploded view	
	PE(S) .. MW .., 0 413 ..	

A19	Exploded view	
	PE(S) .. MW .., 0 413 ..	

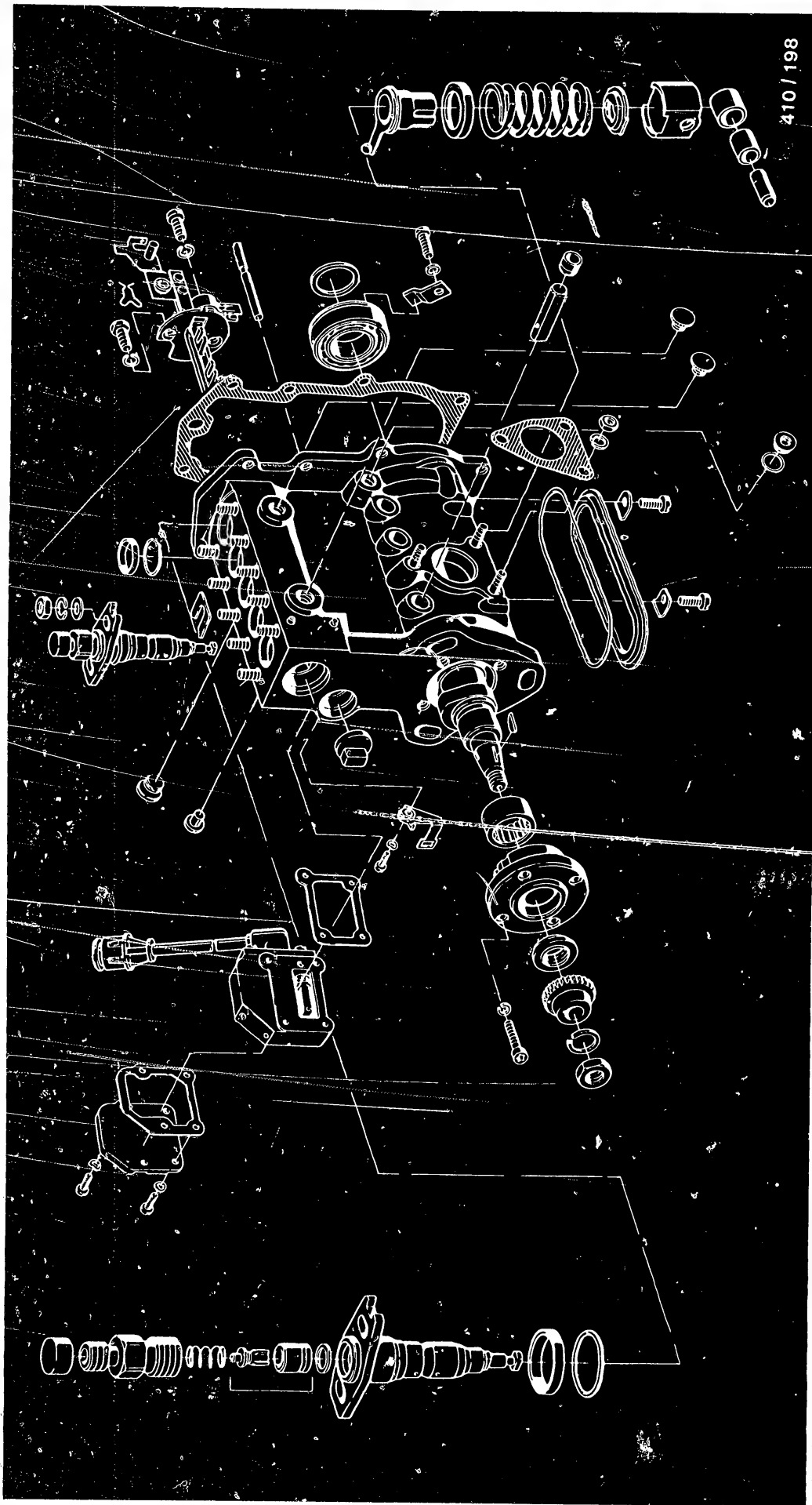

410 / 198

Exploded view of series PE(S)..MW..S 1

Special features:
without capsule and retainer on barrel-and-valve assembly.

A21 Exploded view
PE(S) .. MW .., 0 413 ..

A20 Exploded view
PE(S) .. MW .., 0 413 ..



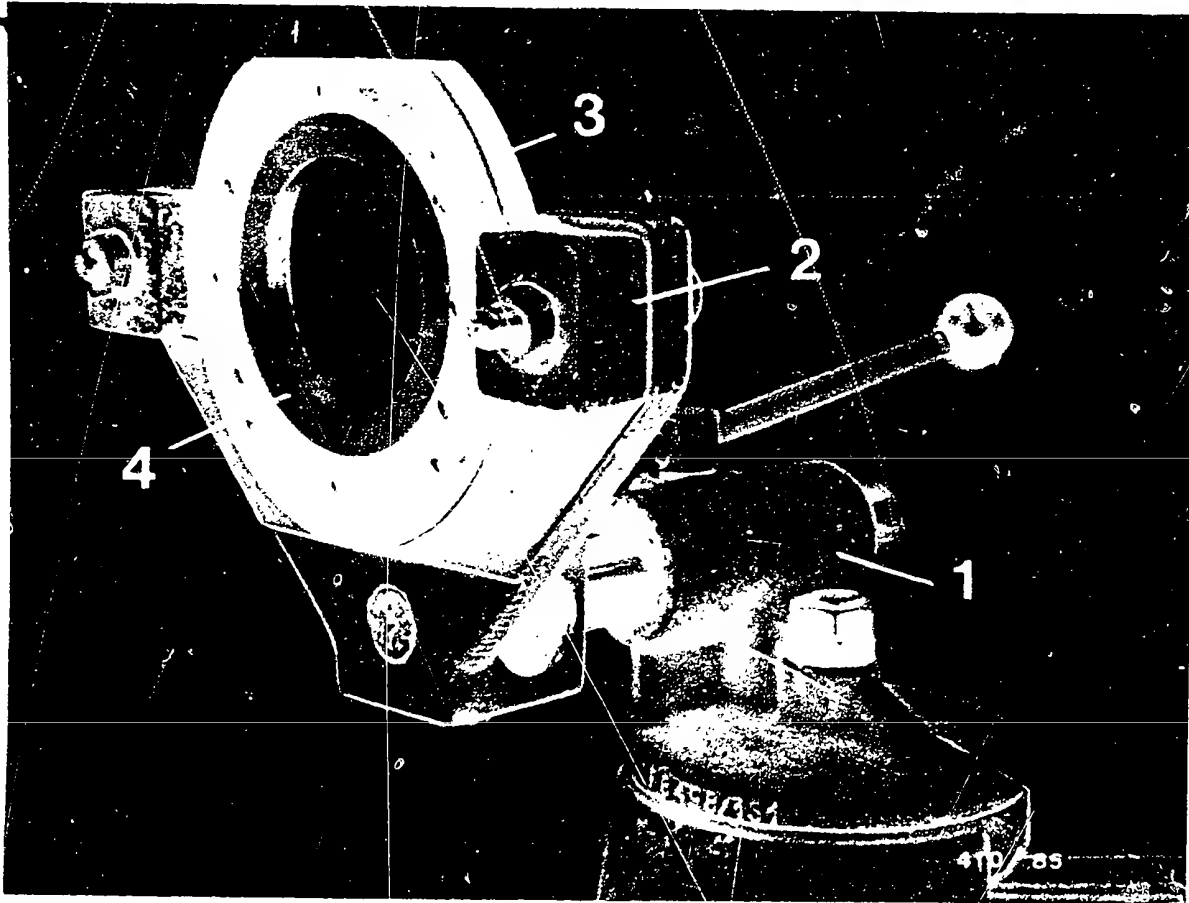

- 1 = Clamping support KDEP 2919
- 2 = Support clamp KDEP 2963
- 3 = Clamping flange to suit version of pump
- 4 = Reduction ring to suit pilot diameter

6. CLAMPING THE INJECTION PUMP

The parts shown in the picture are required for clamping injection pumps with end-flange mounting.

B1

Clamping the injection pump

PE(S) .. MW .., 0 413 ..



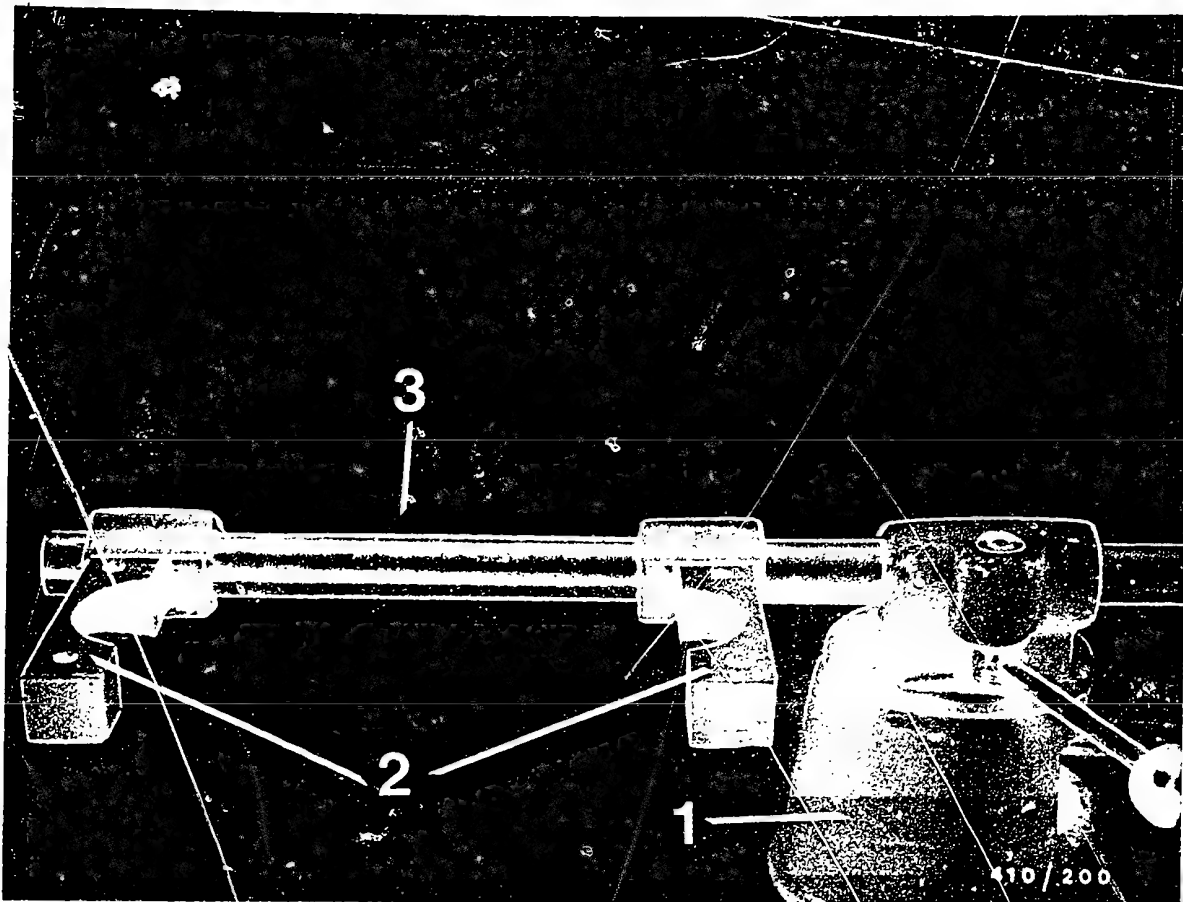

Use the following parts for injection pumps with cradle mounting.

1 = Clamping support KDEP 2919

2 = Clamping parts KDEP 1065

3 = Over-long shaft KDEP 2919/1/13 for
8-cylinder injection pumps

B2

Clamping the injection pump

PE(S) .. MW .., 0 413 ..



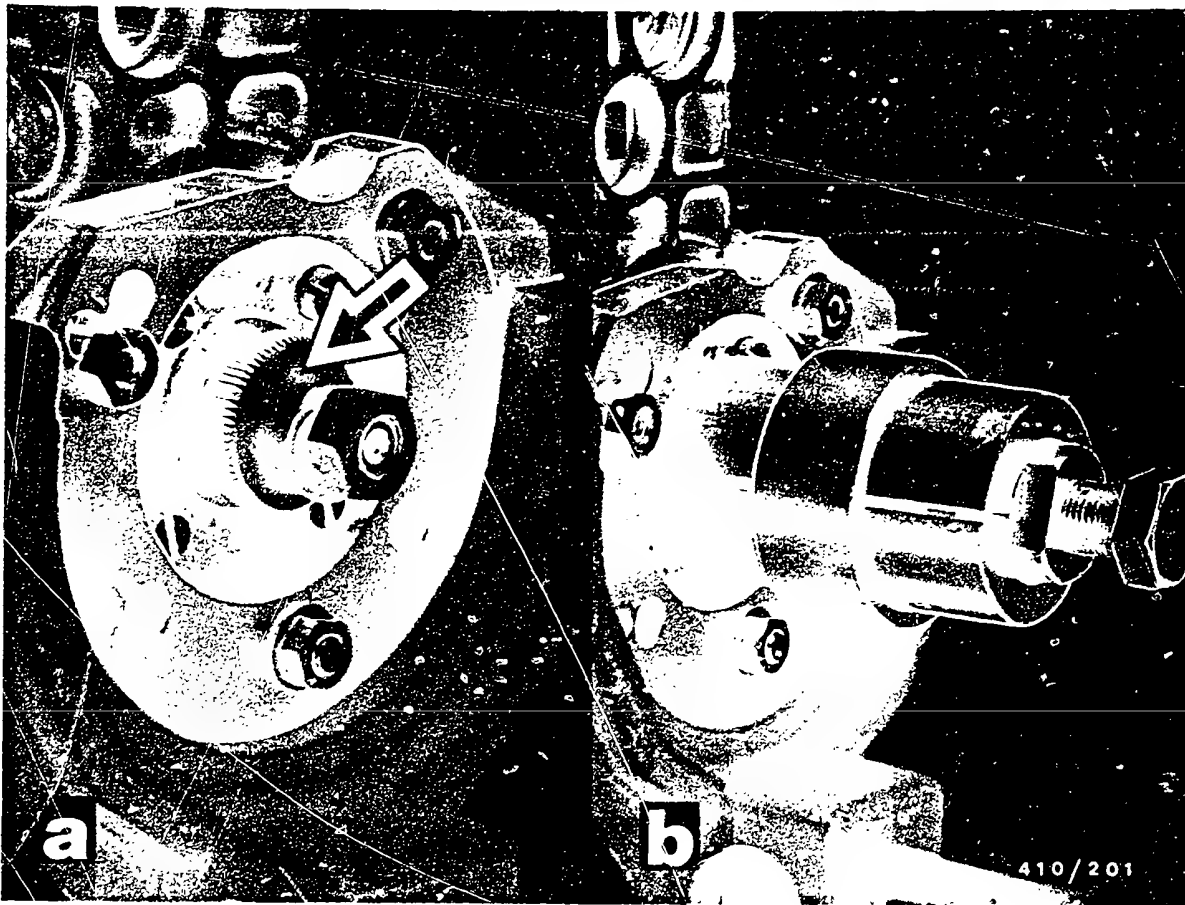

7. DISMANTLING THE INJECTION PUMP

- If mounted, remove drive components (multi-plate clutch, gear or timing device) using suitable commercially available tools.

Exception: DB engine

Pull off drive pinion (see arrow, picture a) using KDEP 1131 (see picture b).

- Put on drive coupling to suit cone diameter of camshaft and tighten.
- Dismantle governor in accordance with respective repair instructions.

B3

Dismantling the injection pump

PE(S) .. MW .., 0 413 ..



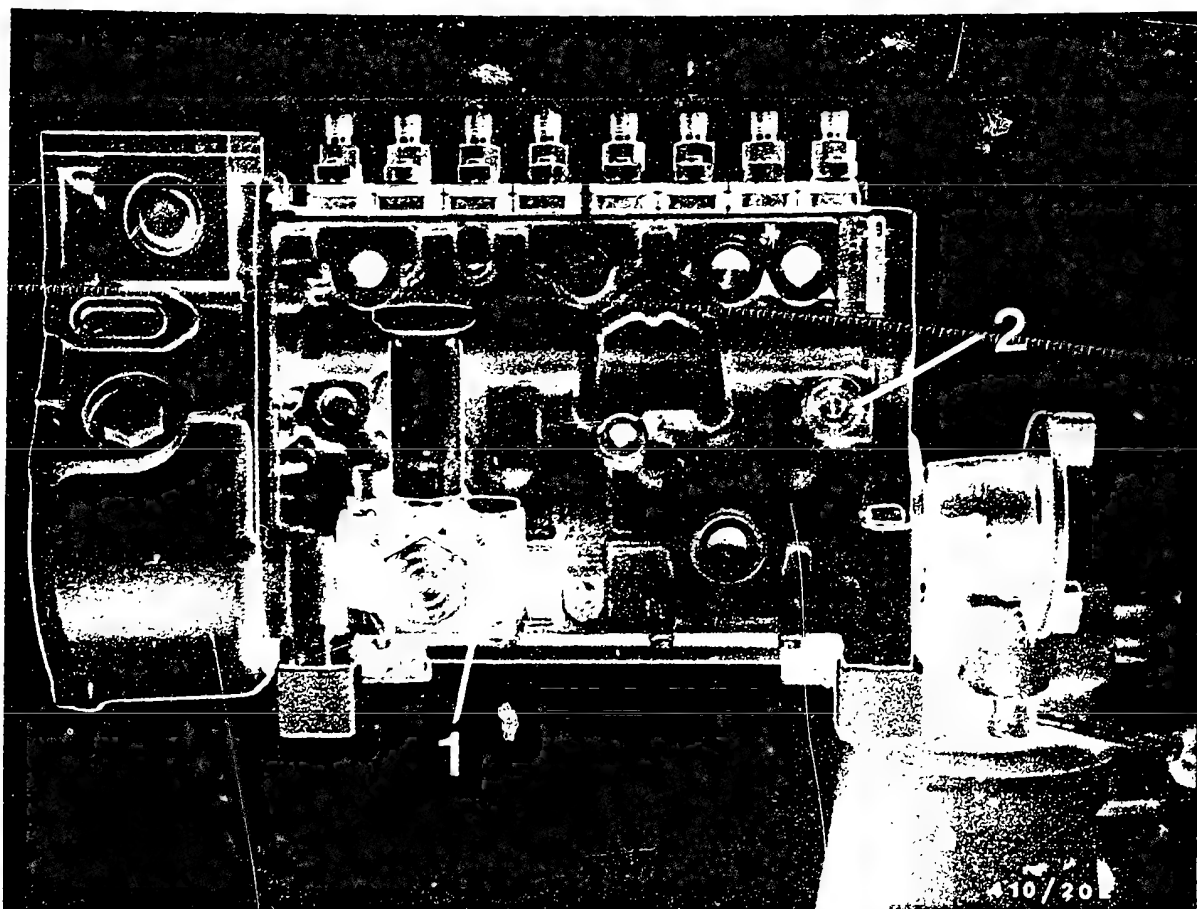

1 = Supply pump

2 = Screw plug

Take off supply pump after removing the hexagon nuts and spring lock washers.

Unscrew screw plug.

Catch escaping oil with container.

Note:

Depending on the size of the injection pump, have a sufficient number of storage boxes available for storing the components.

B4

Dismantling the injection pump

PE(S) .. MW .., 0 413 ..



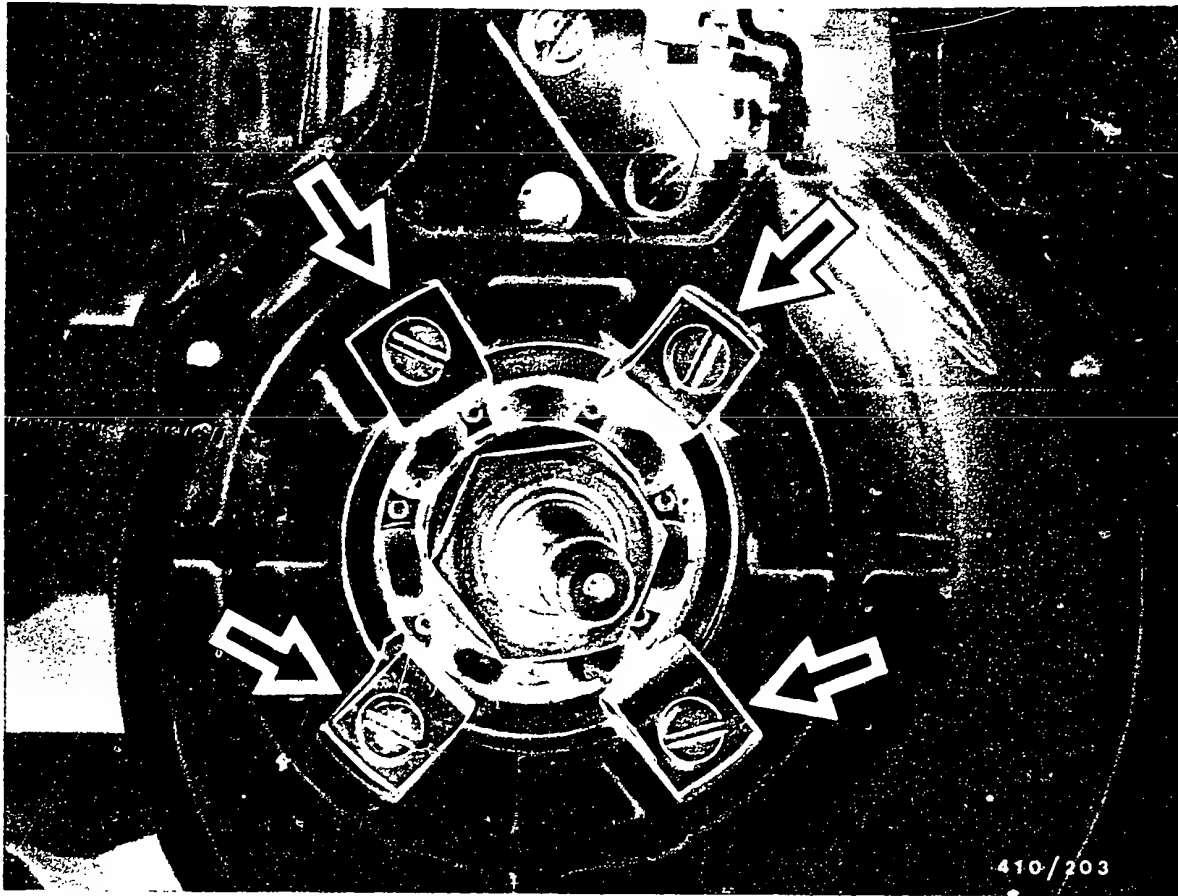

Unscrew governor housing fastening screws and, on version .. S 1000, remove together with holding plates (see picture, arrows).

Separate governor housing from pump housing.

B5

Dismantling the injection pump
PE(S) .. MW .., 0 413 ..



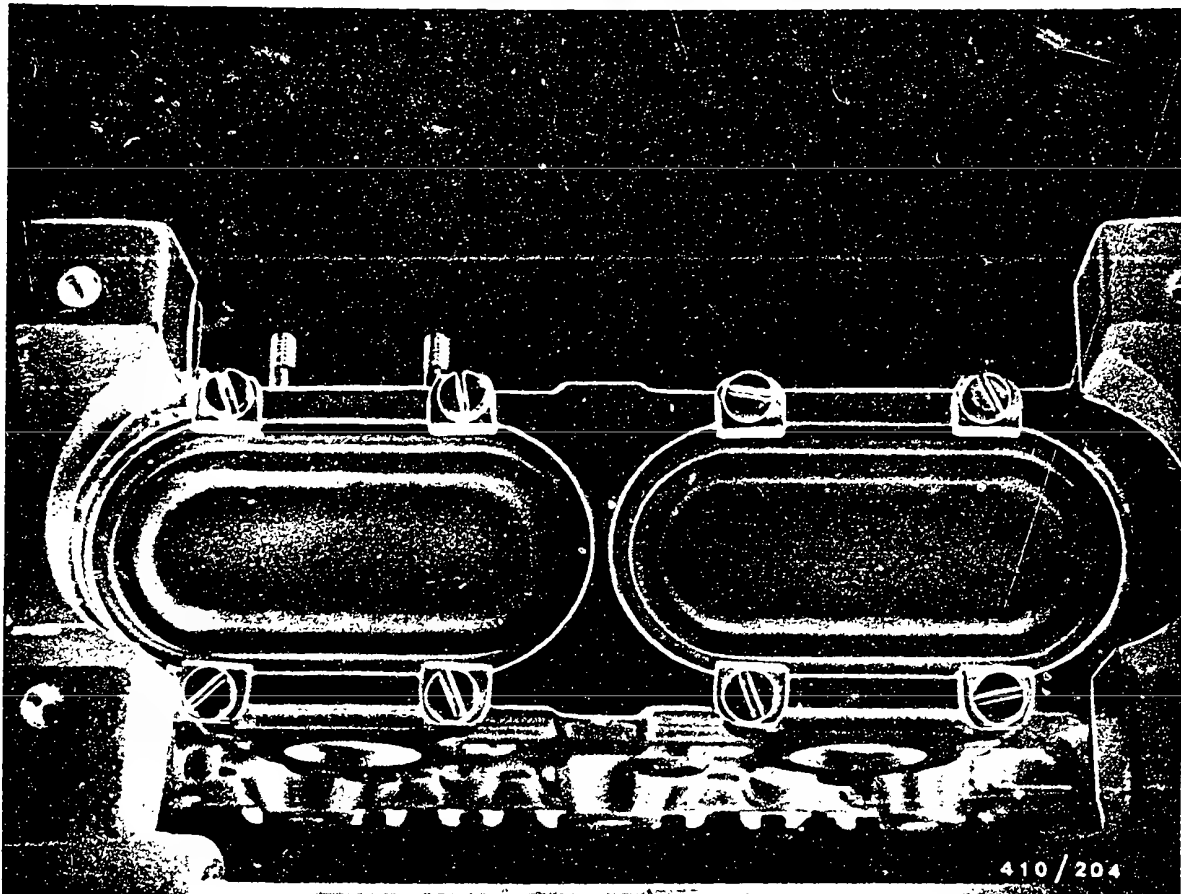

Tilt the injection pump.
(Delivery-valve holders pointing downward)

Unscrew fastening screws of base closing covers and
remove together with holding plates.

Take off base closing covers.

B6

Dismantling the injection pump
PE(S) .. MW .., 0 413 ..



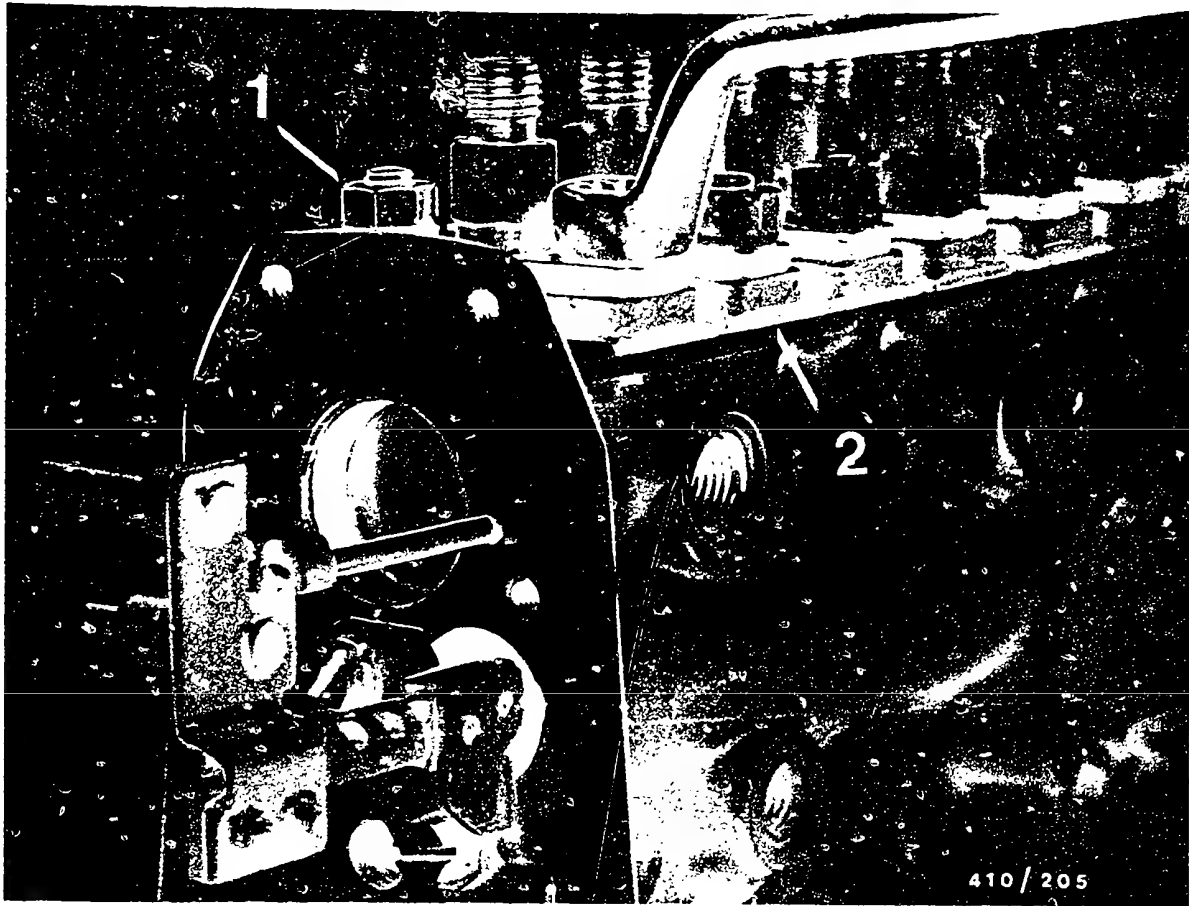

1 = Hexagon nuts

2 = Prestroke shims

Position the injection pump upright again (see picture).

Loosen hexagon nuts by approx 3 turns and take out split prestroke adjusting shims on both sides.

B7

Dismantling the injection pump

PE(S) . . . MW . . . 0 413 . . .



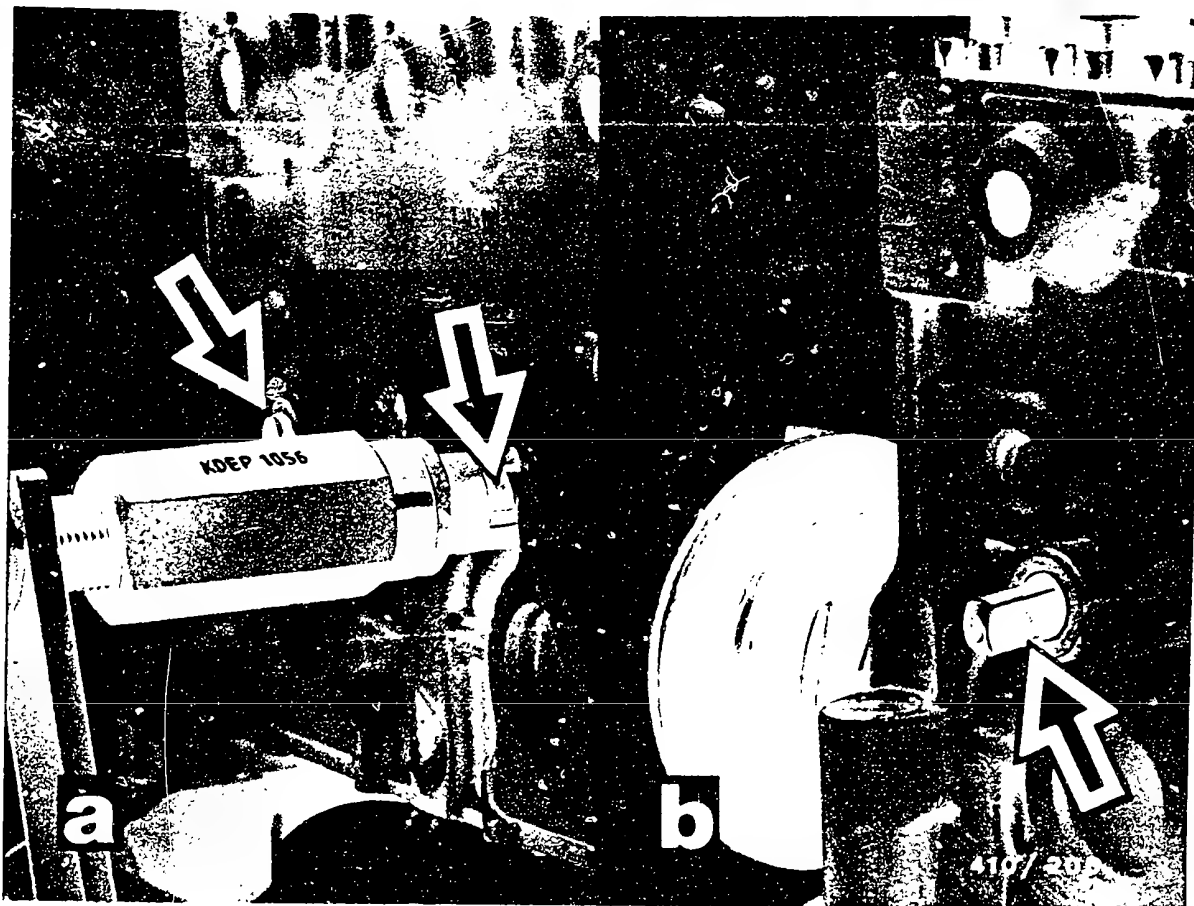

Remove side capsules (see picture a, arrows) using puller KDEP 1056.

Remove spacer pin (see picture b, arrow).

Tilt injection pump (delivery-valve holders pointing downward).

B8

Dismantling the injection pump

PE(S) .. MW .., 0 413 ..



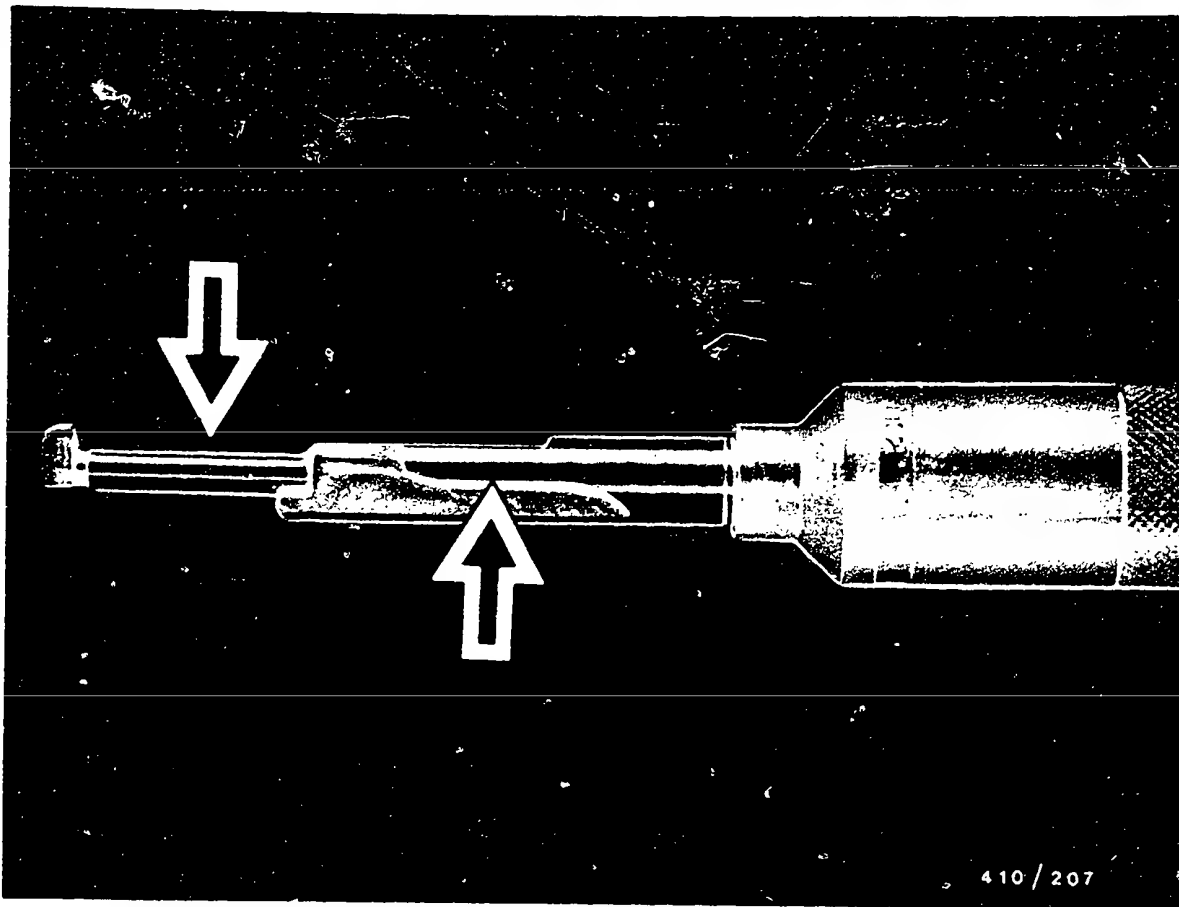

7.1 Mounting the tappet holders

Turn rotatable handle of tappet holder
KDEP 1051 (8 mm stroke) or
KDEP 1068 (10 mm stroke)
as far as it will go in a counterclockwise direction.

Coat holding edges and guide piece of tappet holder with
grease (see picture, arrows).

B9

Dismantling the injection pump
PE(S) .. MW .., 0 413 ..



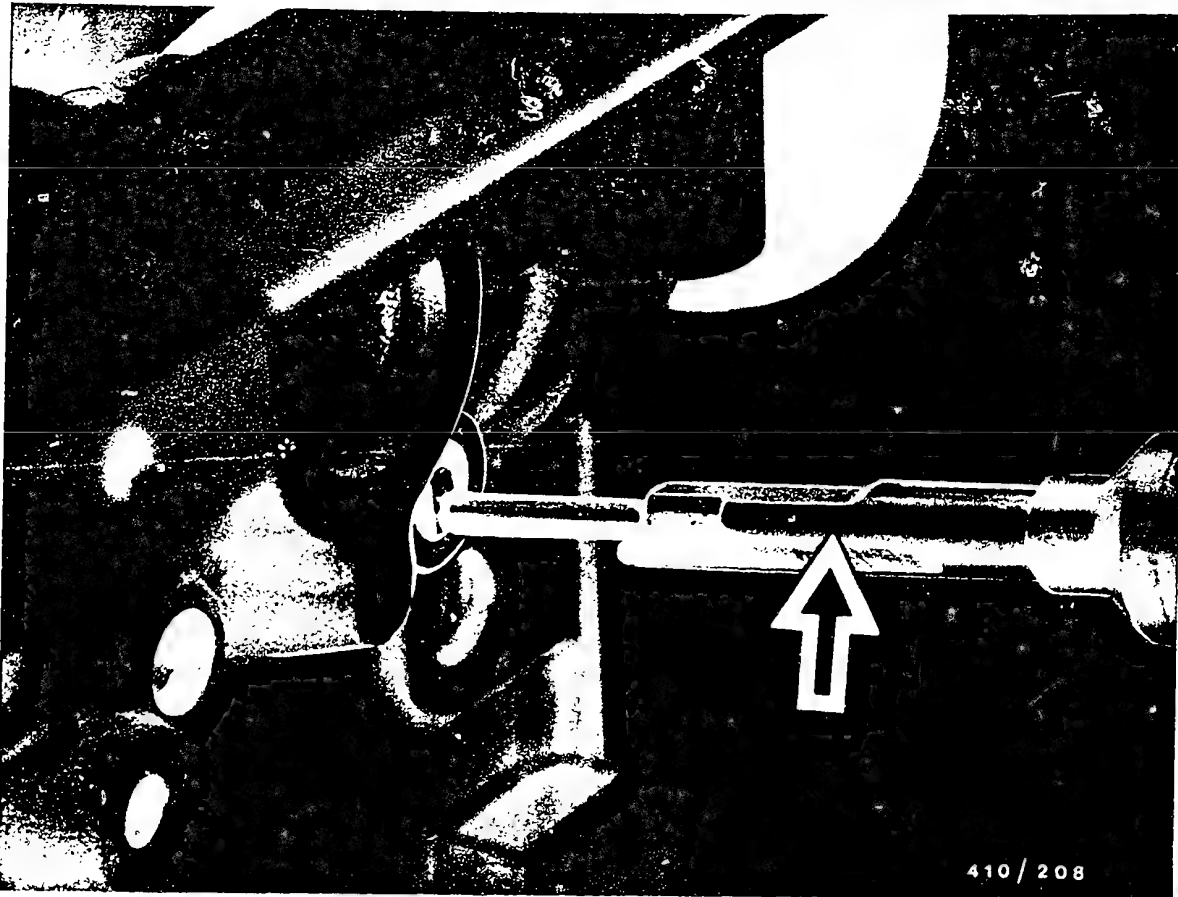

By turning the camshaft, bring roller tappet of cylinder 1 into TDC position.

With holding edges to the top (see picture), introduce tappet holder into lateral bore of spacer pin.

Press in tappet holder until resistance can be felt; do not knock in.

Roller tappet is held by the right-hand edge of the tappet holder.

B 10

Dismantling the injection pump

PE(S) .. MW .., 0 413 ..



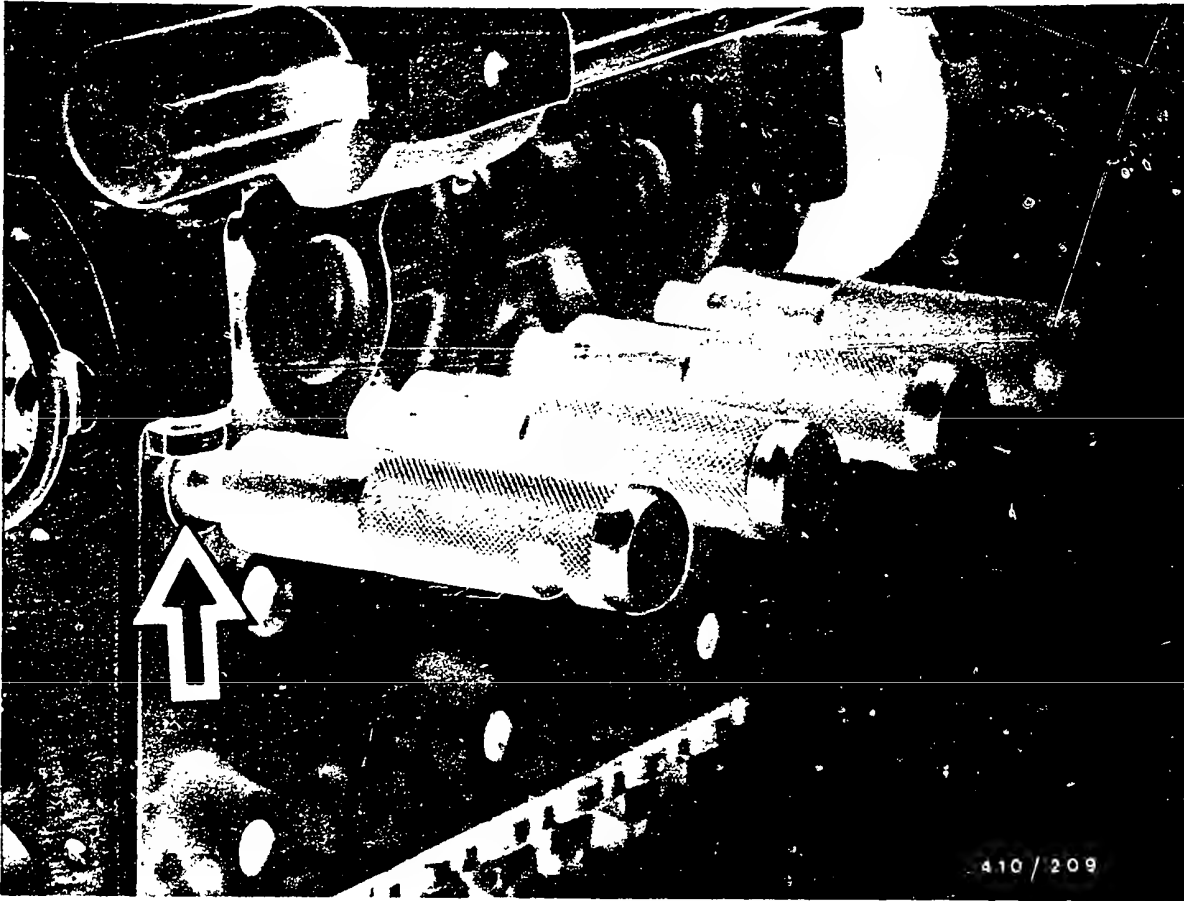

Turn camshaft further until roller tappet of cylinder 2 is in TDC position.

Now press in (do not knock in) tappet holder until it comes up against the housing (see picture, arrow).

Both roller tappets (barrels 1 and 2) are lifted off the camshaft and fixed in position.

The remaining roller tappets are fixed in position in the same manner.

B 11

Dismantling the injection pump

PE(S) .. MW .., 0 413 ..



Note:

On the 5-cylinder injection pump, due to a greater distance between the plunger-and-barrel assemblies of barrels 4 and 5, only roller tappet 5 is fixed in position with tappet holder 3.

B 12

Dismantling the injection pump

PE(S) .. MW ... 0 413 ..



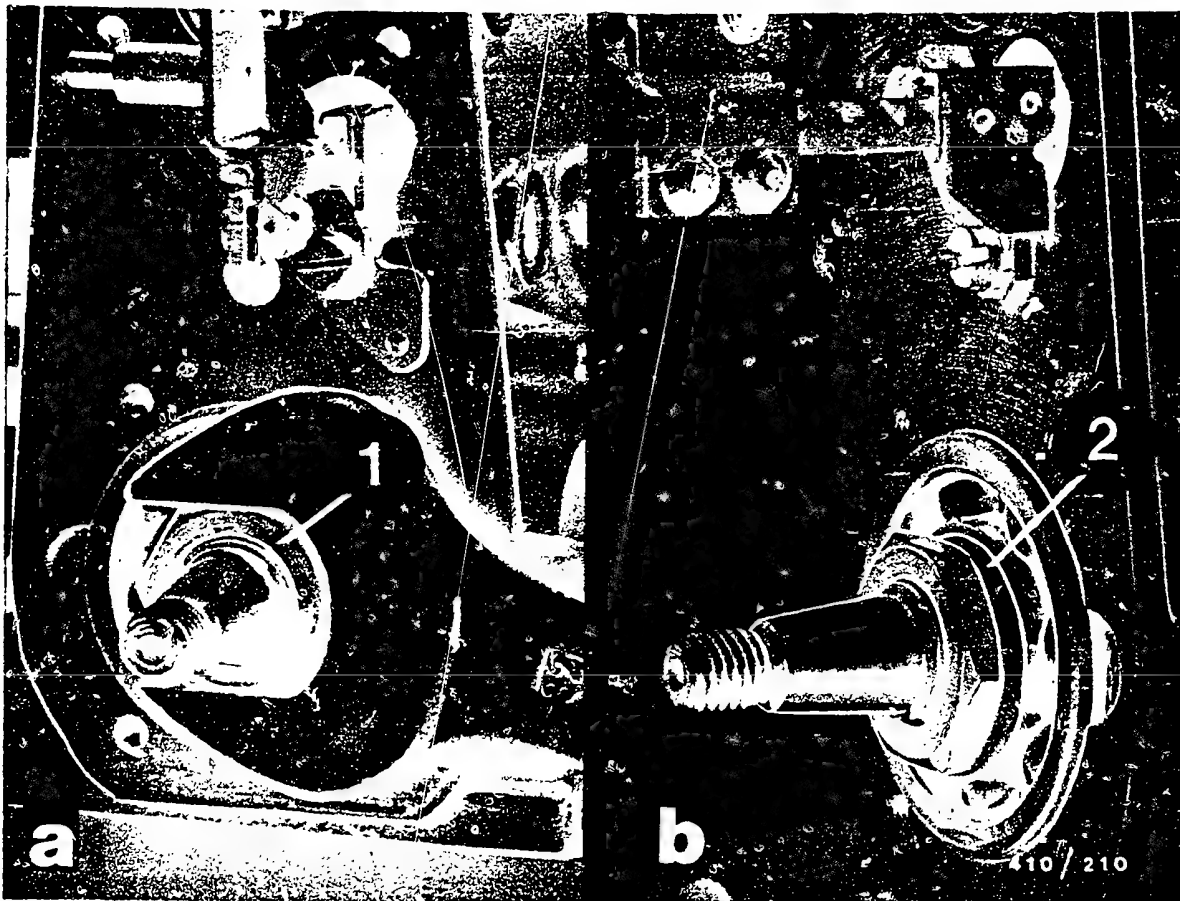

1 = Hexagon nut

2 = Washer

Remove governor-end hexagon nut on PE(S)..MW..S1000 and S1500.

When doing this, hold drive coupling with holding wrench KDEP 2906 or KDEP 2885.

Remove washer.

B 13

Dismantling the injection pump

PE(S) .. MW .., 0 413 ..



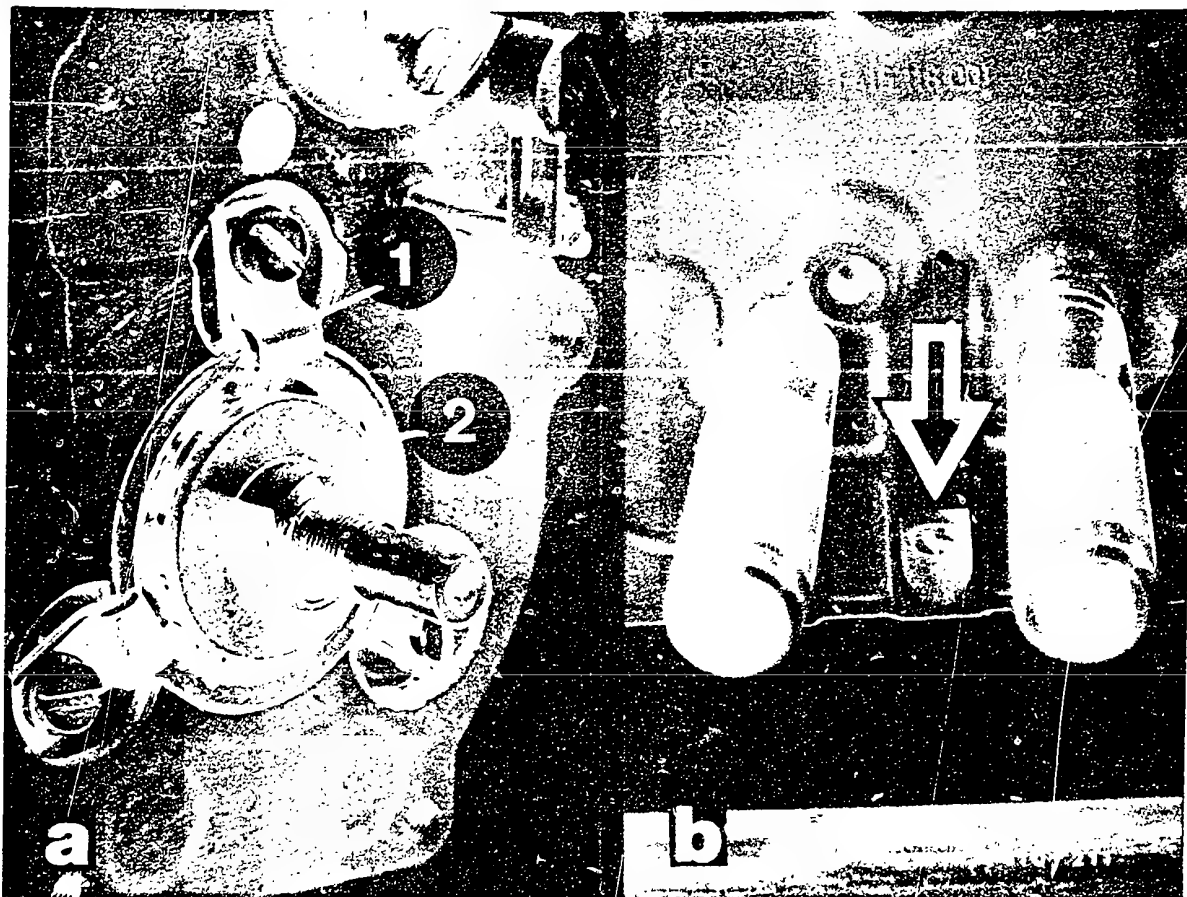

1 = Holding plates
2 = Washers

Remove holding plates and washer on PE(S).. MW.. S1 (see picture a).

Unscrew intermediate bearing fastening screws (if applicable) (see picture b, arrow).

B14

Dismantling the injection pump

PE(S) .. MW .., 0 413 ..



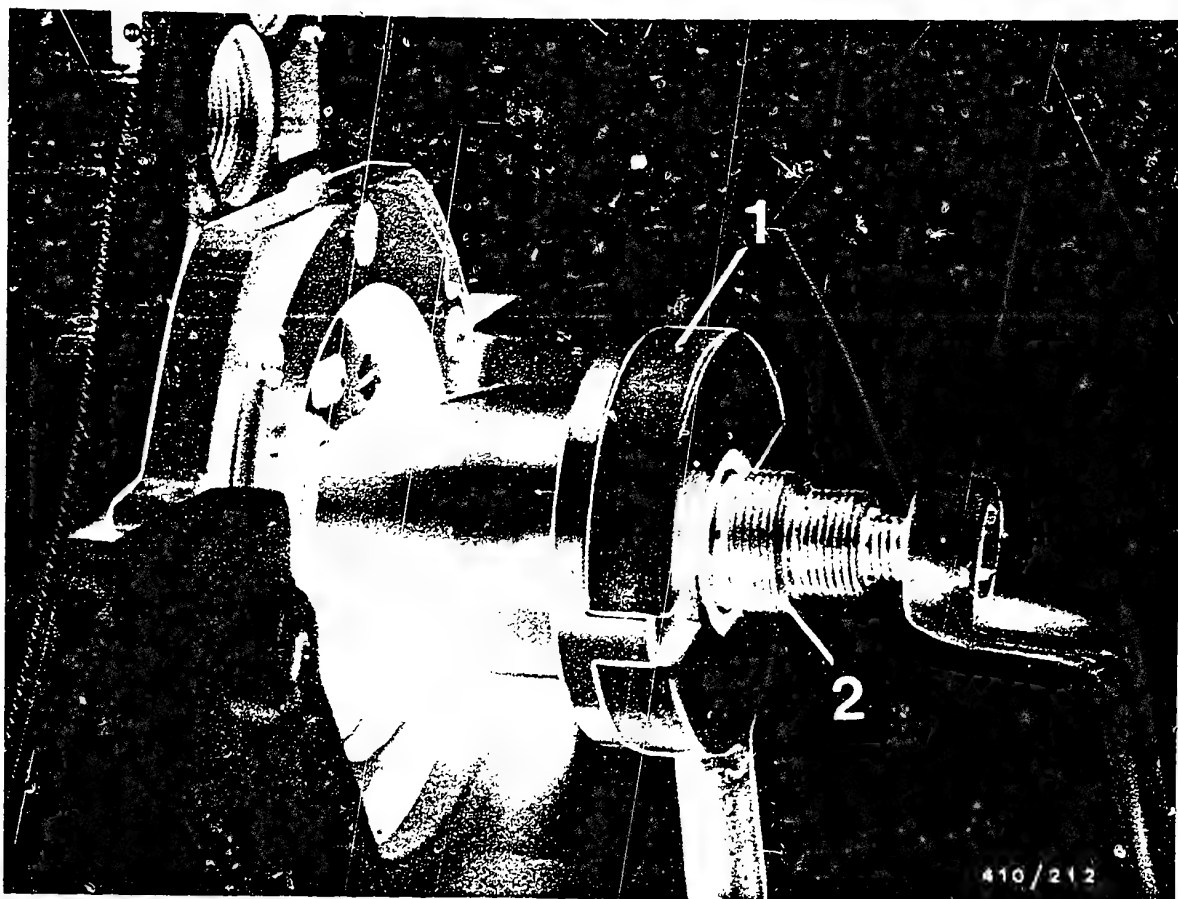

1 = Holding wrench

2 = Puller KDEP 2918

7.2 Removing the drive coupling

Using holding wrench KDEP 2906 or 2885 and puller KDEP 2918, loosen drive coupling from camshaft cone (see picture) and remove.

Remove Woodruff key.

B15

Dismantling the injection pump

PE(S) .. MW .., 0 413 ..



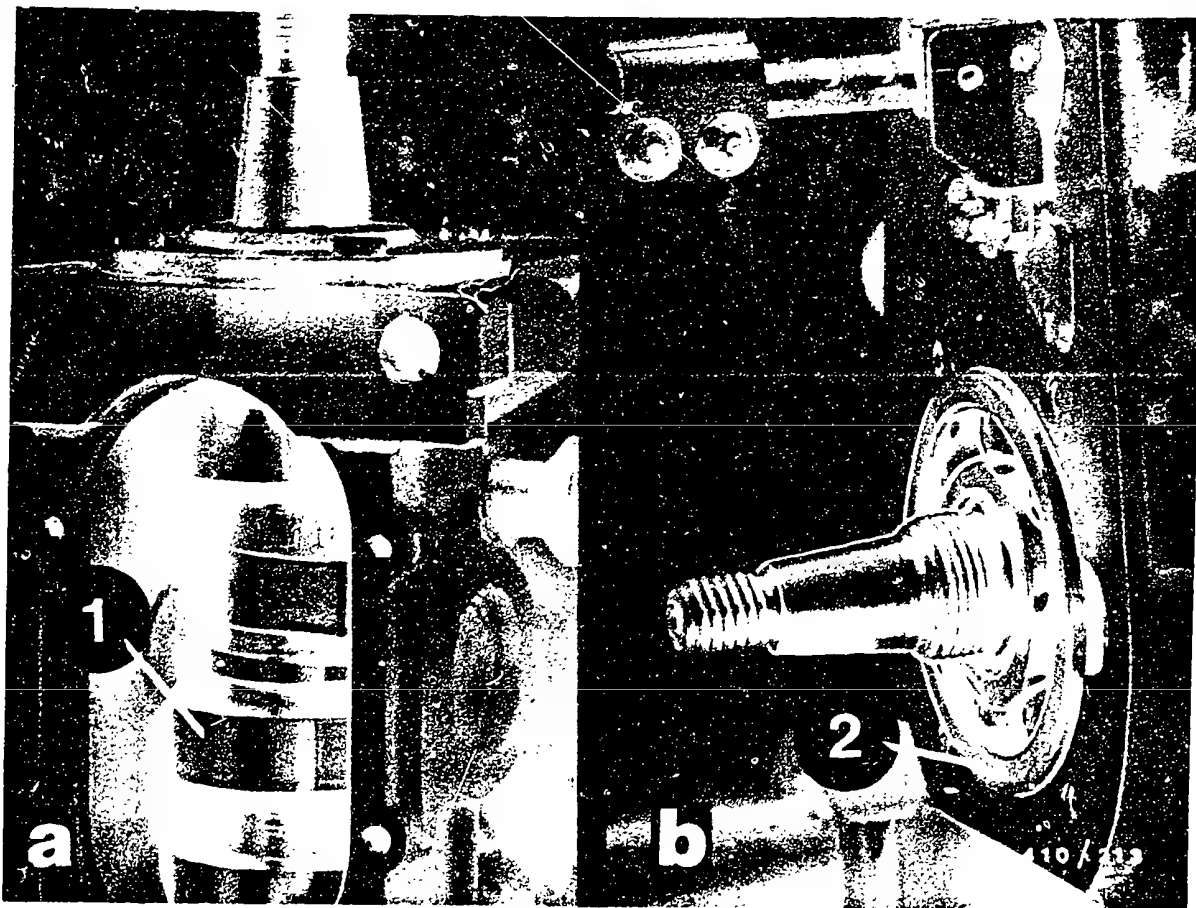

1 = Camshaft

2 = Deep-groove ball bearing

7.3 Removing the camshaft

Remove housing from clamping support.

Under an arbor press, press out camshaft with intermediate bearing (if applicable) and deep-groove ball bearing in direction of governor.

B 16

Dismantling the injection pump

PE(S) .. MW .., 0 413 ..



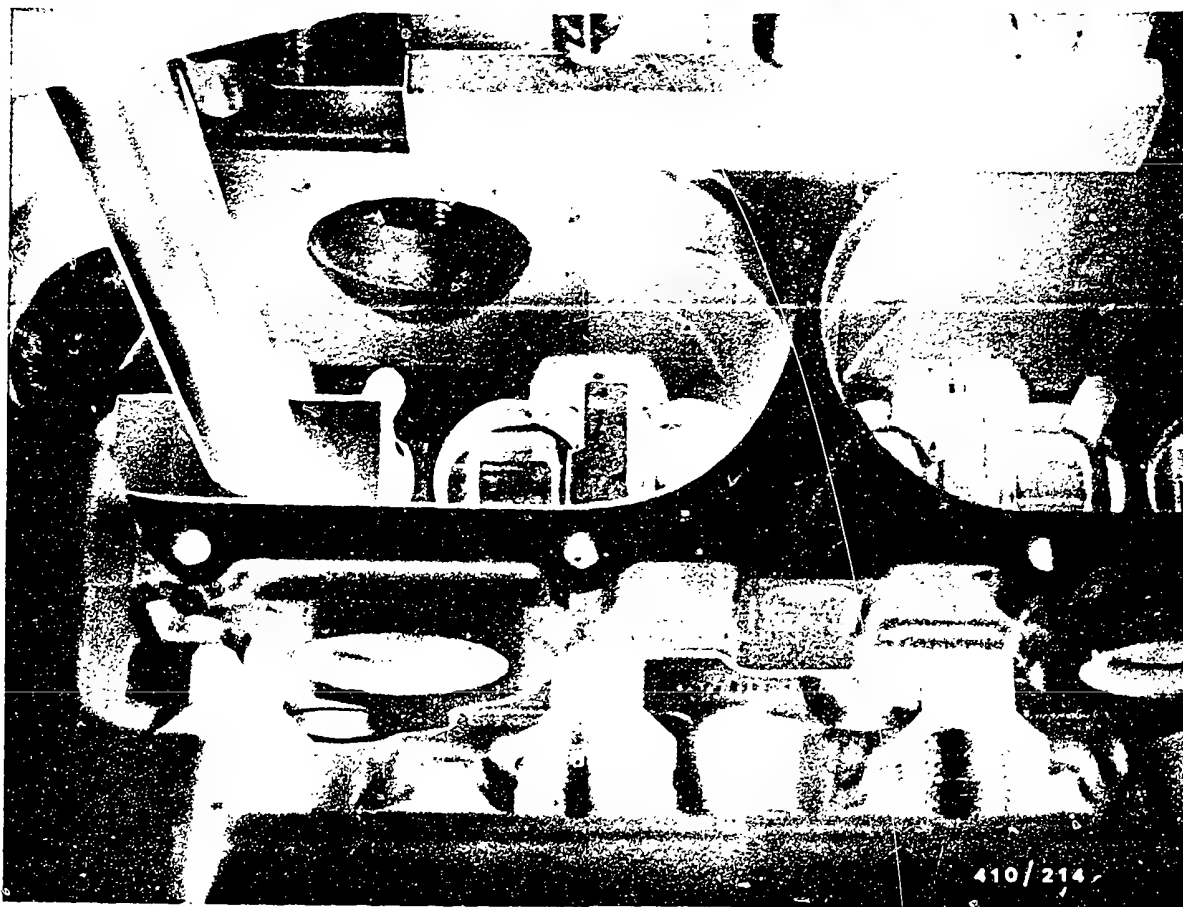

7.4 Removing the tappet holders

Mount assembly device KDEP 1505 on pump.

Place double thrust piece of device on rollers of roller tappets and press down (see picture).

Remove both tappet holders by turning the handle in a clockwise direction.

After removing the tappet holders, relax the plunger spring.

Remove assembly device KDEP 1505.

B 17

Dismantling the injection pump

PE(S) .. MW .., 0 413 ..



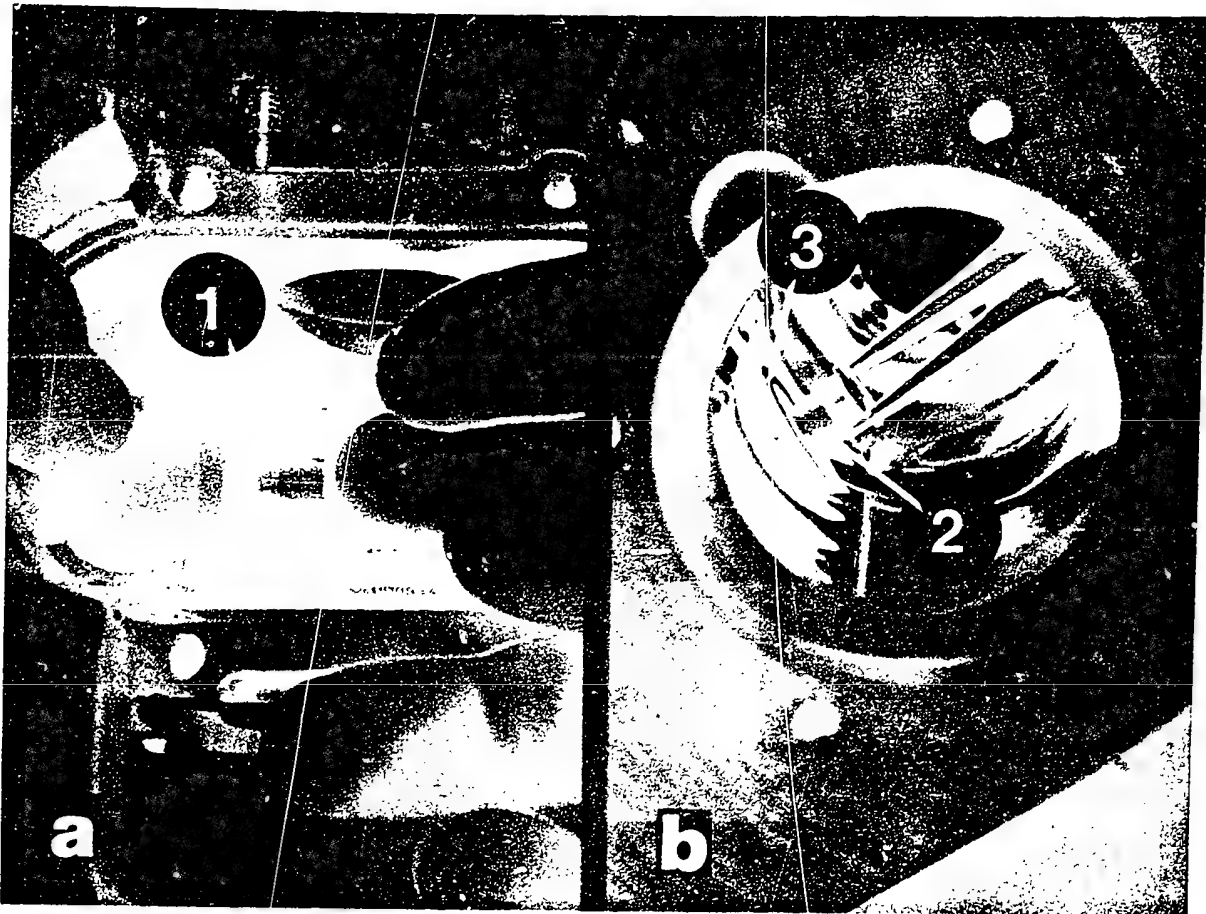

1 = Roller tappet

2 = Pump plunger

3 = Spring seat

7.5 Partial removal of barrel assembly

Take roller tappets out of tappet guides (picture a).

Remove pump plungers and spring seats and lay to one side (picture b).

Note:

Pump plungers must not be mixed up, i.e. keep all components belonging to the same barrel in one box.



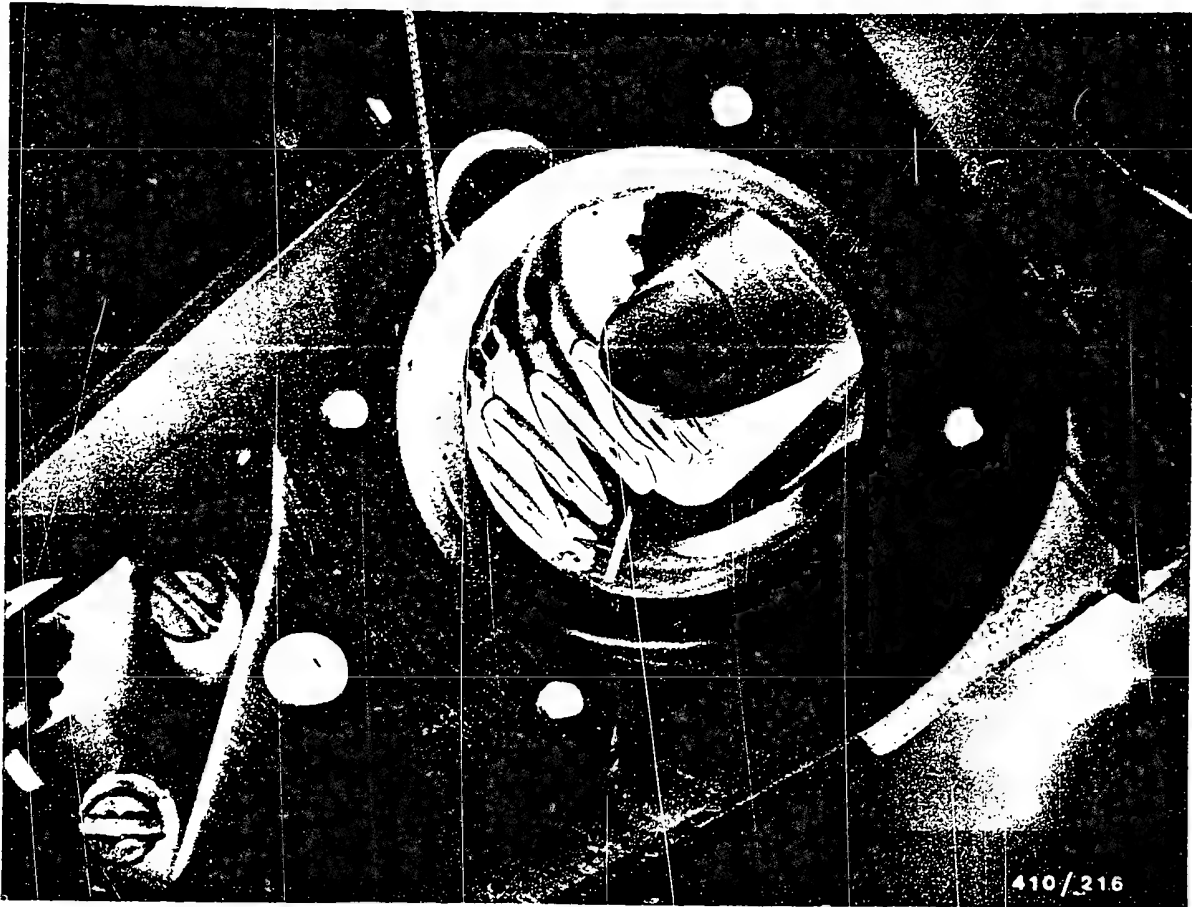

Take out compression springs (see picture).

B 19

Dismantling the injection pump

PE(S) .. MW .., 0 413 ..



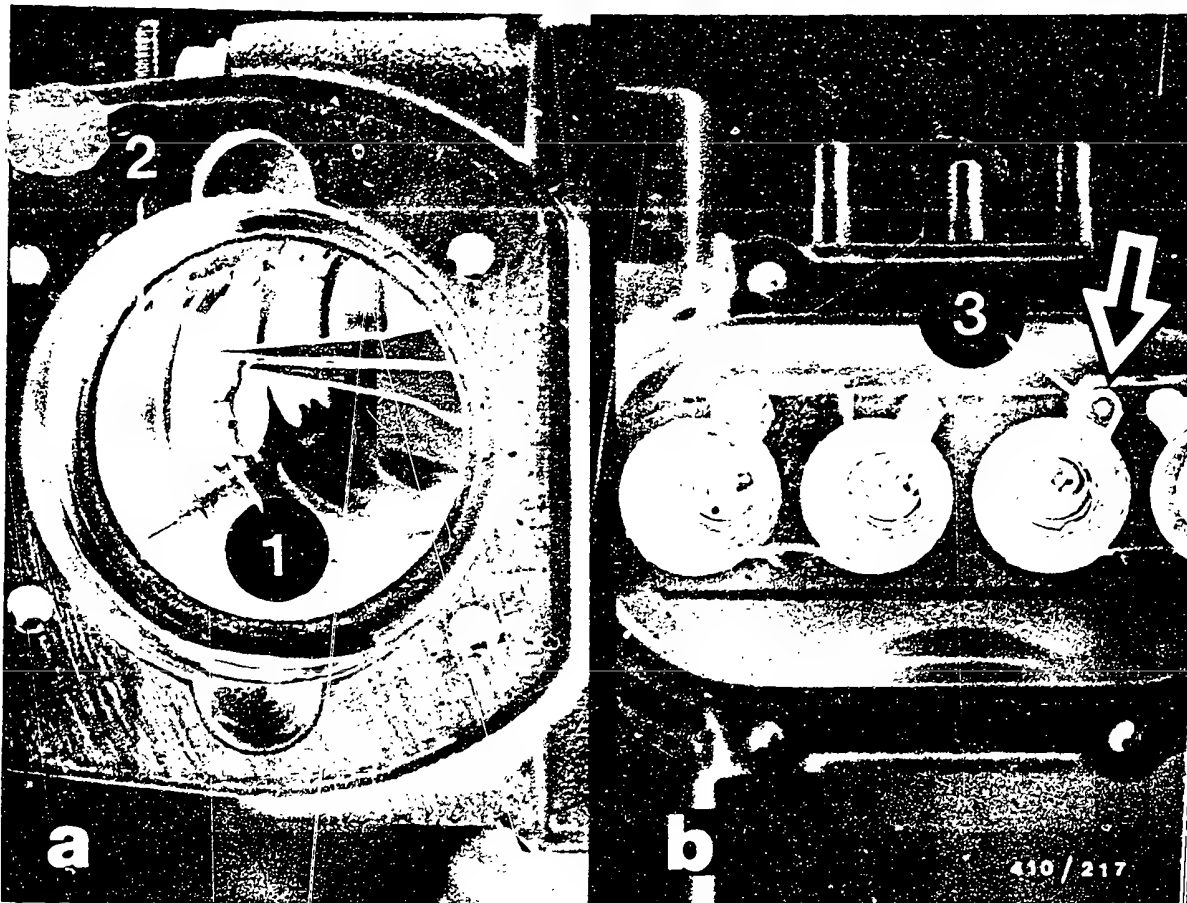

1 = Control sleeve
2 = Spring seat

3 = Control bushing

Using pointed pliers, remove control sleeve and spring seat together (see picture a).

When doing this, the control sleeve link and the housing recess must be in alignment (see picture b, arrow).

B20

Dismantling the injection pump

PE(S) .. MW .., 0 413 ..



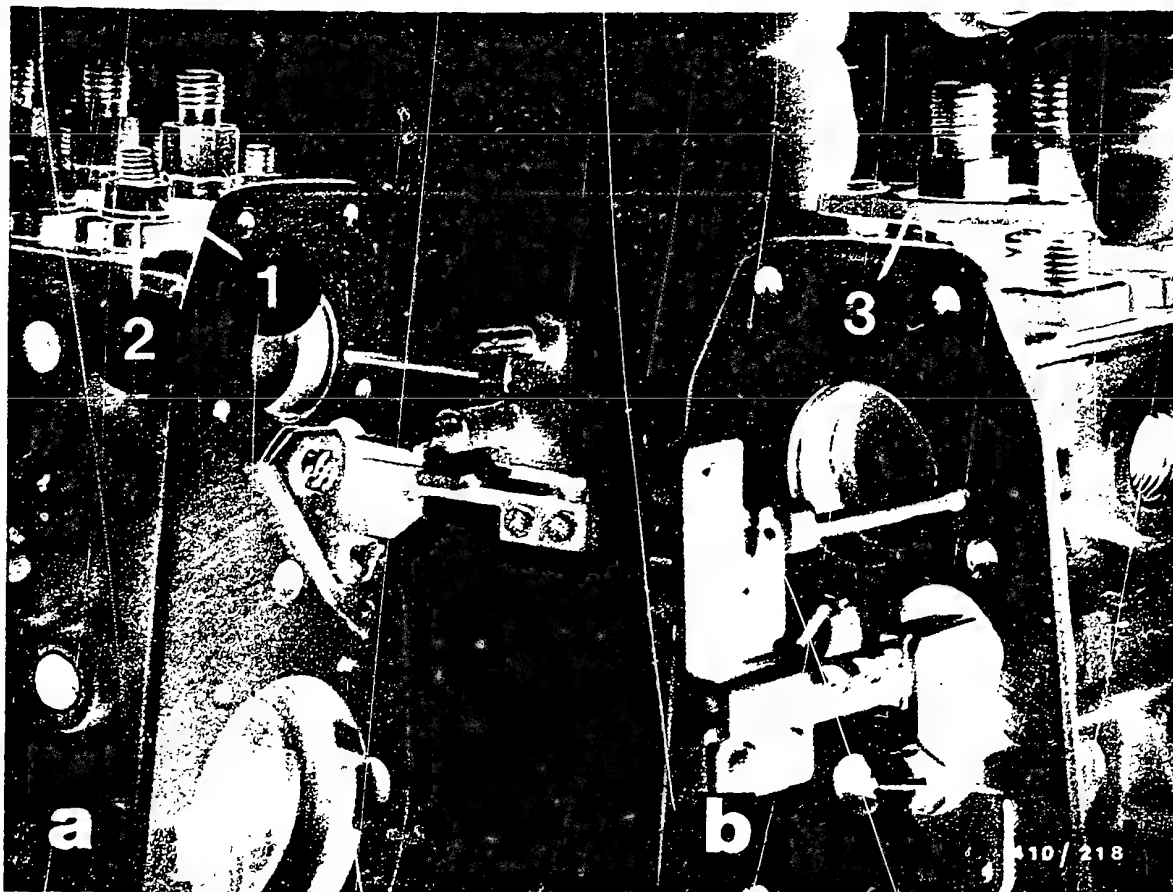

1 = Hexagon nut
2 = Spring lock washer

3 = Support plate

7.6 Removing the barrel-and-valve assembly

Position the injection pump vertically.

Remove hexagon nuts, spring lock washers and support plate.

B21

Dismantling the injection pump
PE(S) .. MW .., 0 413 ..



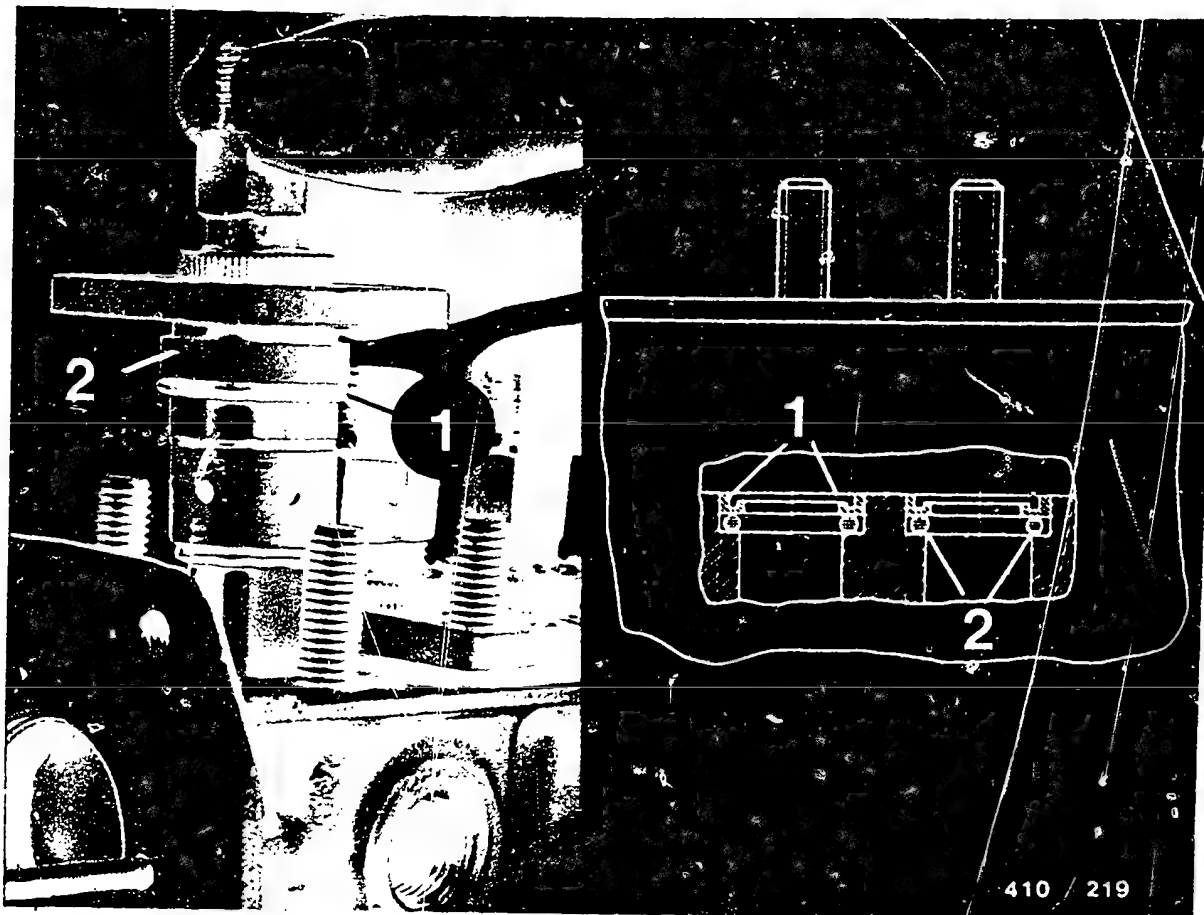

1 = O-ring

2 = Spacer ring

Remove the complete barrel-and-valve assembly with O-ring and spacer ring (see picture a) and lay to one side with the corresponding plunger.

If necessary (loose or damaged), remove spacer ring and O-ring from housing (see picture b).

B22

Dismantling the injection pump

PE(S) .. MW .., 0 413 ..



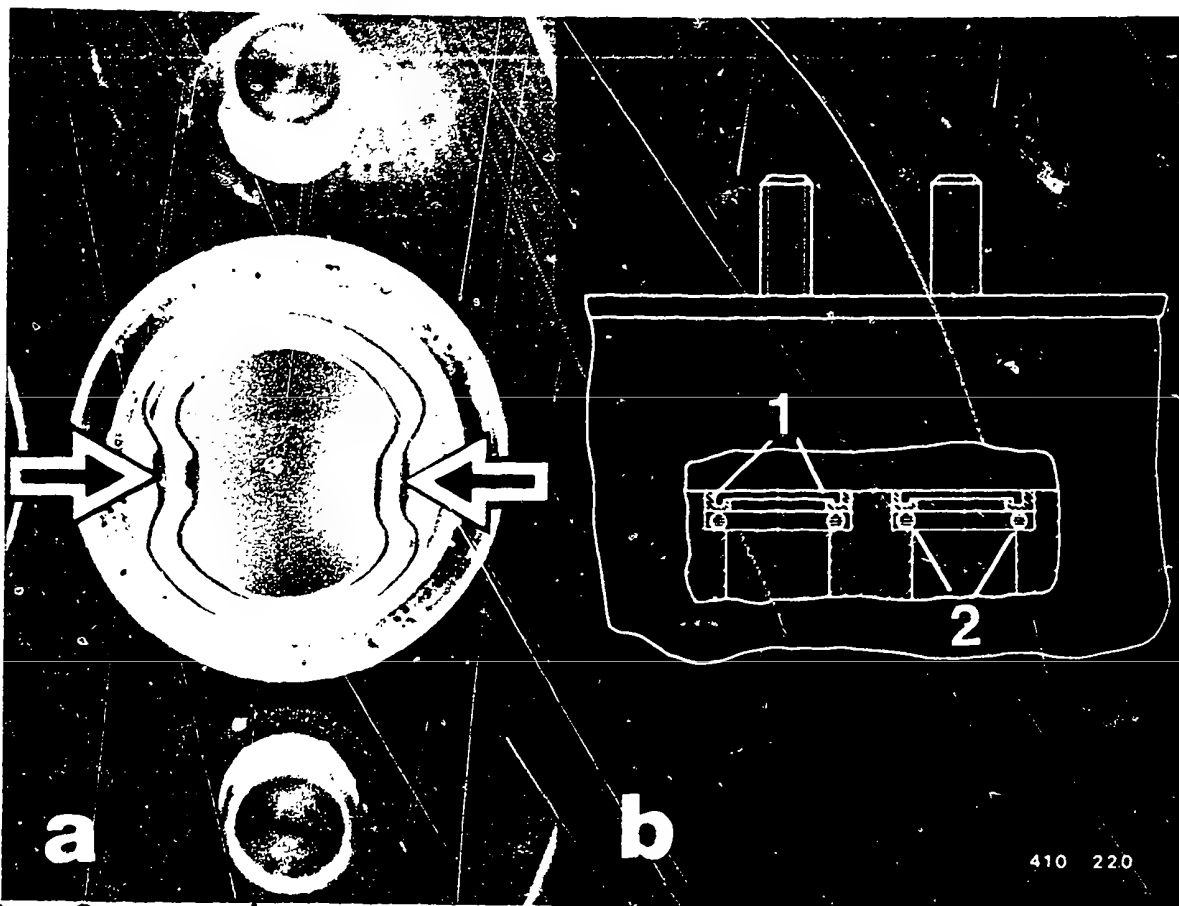

1 = Spacer ring

2 = O-ring

Removing the spacer ring and O-ring.

Using screwdriver, press spacer ring in pump housing toward center of bore (see picture a, arrows).

Warning:

Do not damage housing.

Knock out spacer ring in direction of top edge of housing.

Remove O-ring.

410 220

B23

Dismantling the injection pump

PE(S) .. MW .., 0 413 ..



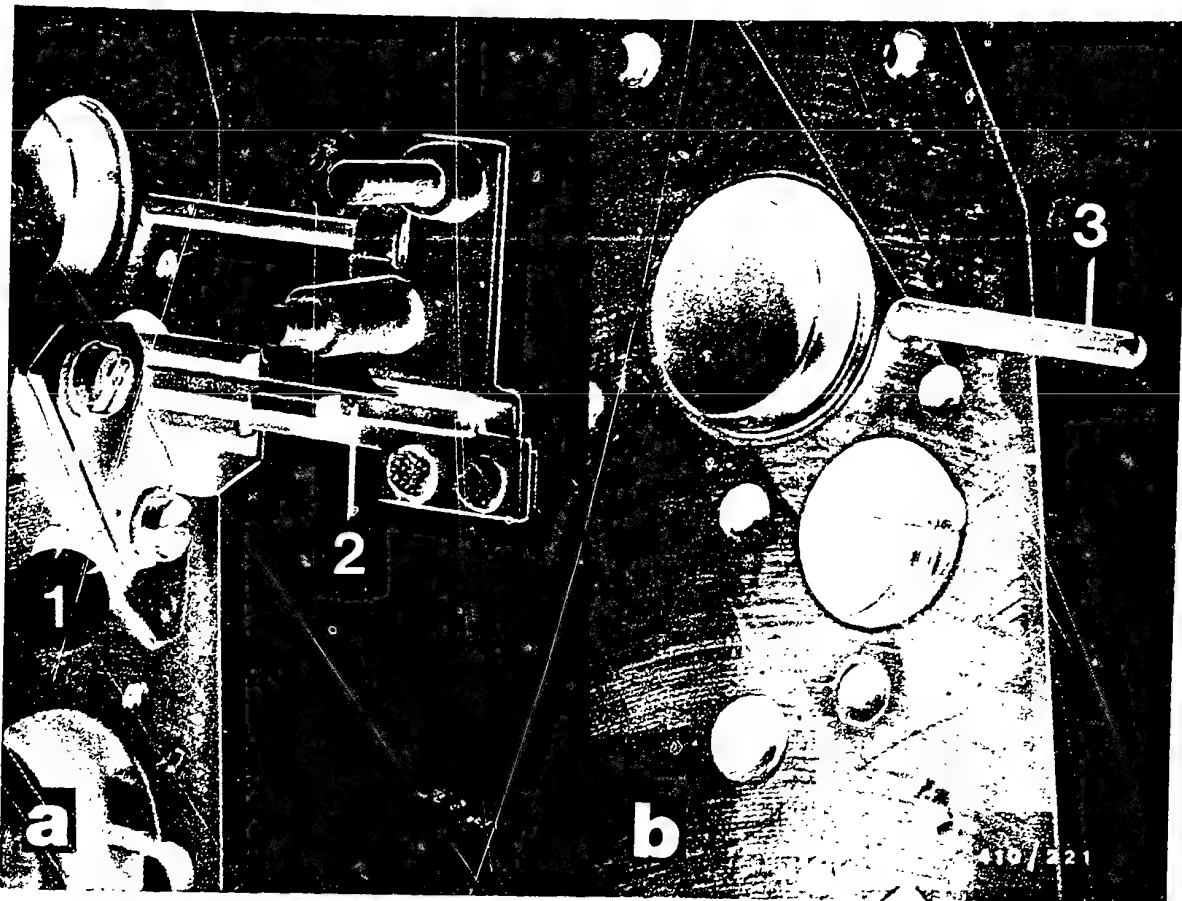

1 = Fastening screws
2 = Control rod

3 = Guide pin

7.7 Removing the control rod

Remove the control-rod travel sensor, if applicable.

Remove short-circuit ring from control rod.

Unscrew fastening screws and remove control rod.

Note:

During the following operations, pay attention to the guide pin (danger of breakage).

B24

Dismantling the injection pump
PE(S) .. MW .., 0 413 ..



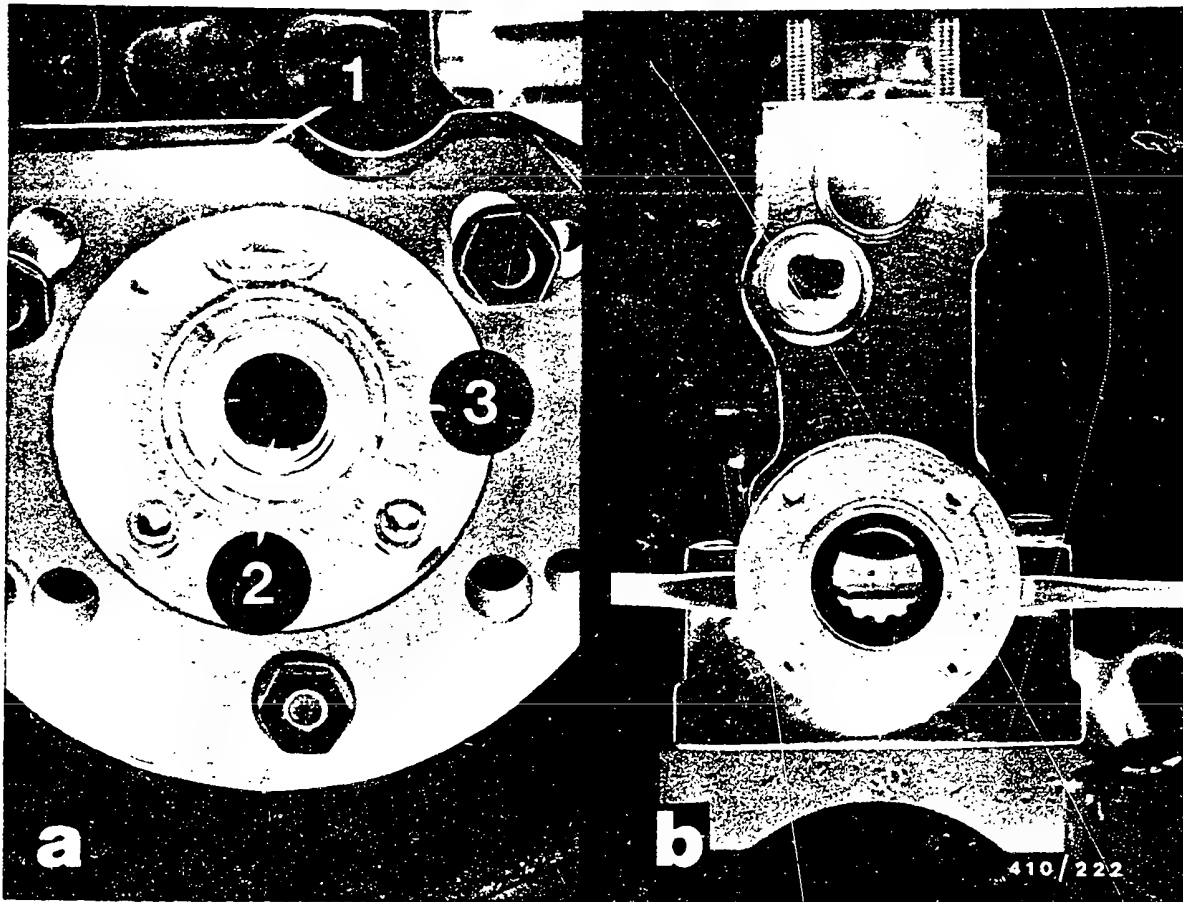

1 = Clamping flange
 2 = Cylindrical-roller bearing

3 = Radial-lip-type
 oil seal

7.8 Removing the bearing end plate

Unscrew bearing end plate fastening screws.

Using 2 screwdrivers, uniformly lever off the bearing end plate (see picture b).

Remove radial-lip-type oil seal.

Press out the cylindrical-roller bearing using appropriate mandrel.

Note:

To do this, unscrew end-flange-mounted injection pumps from clamping flange.

C1

Dismantling the injection pump

PE(S) .. MW .., 0 413 ..



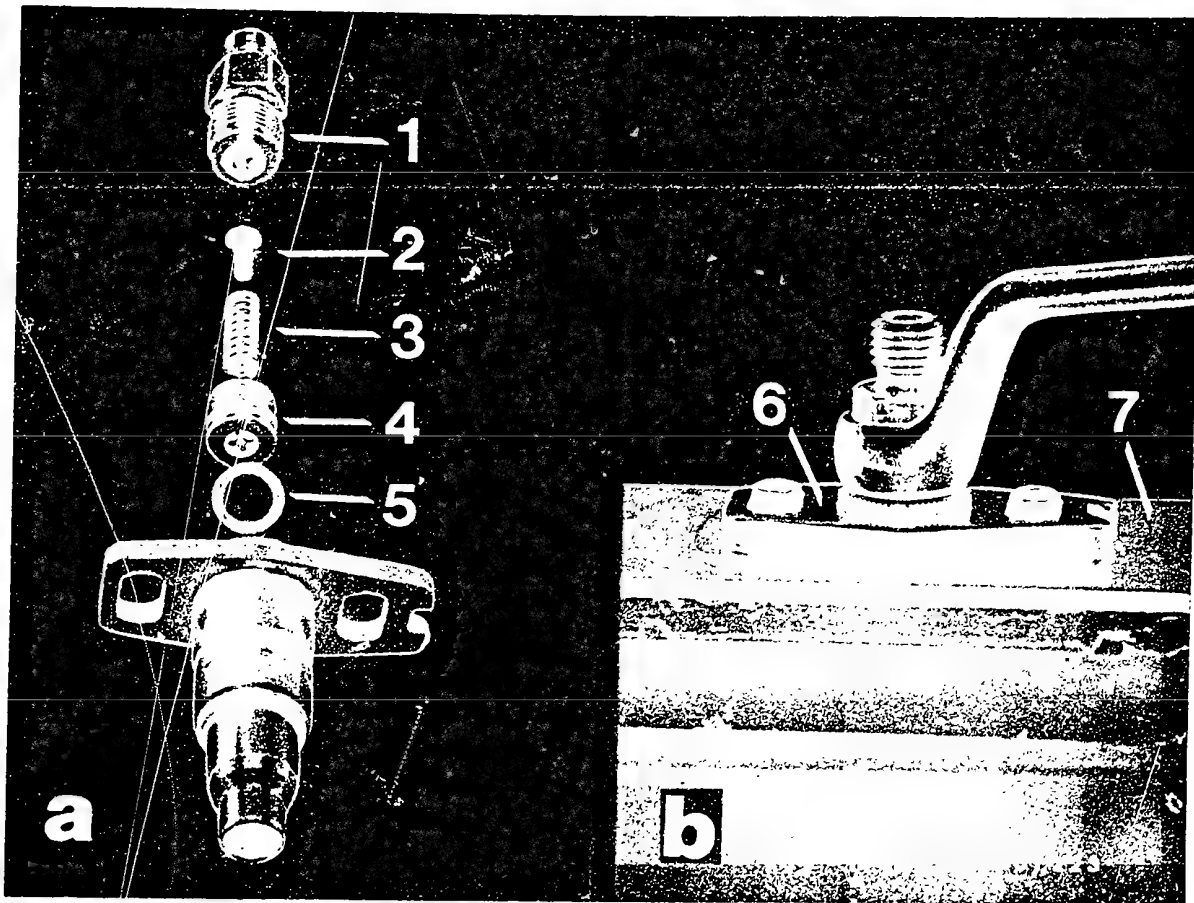

1 = Delivery-valve holder
 2 = Filler piece
 3 = Compression spring
 4 = Delivery valve

5 = Gasket
 6 = Barrel-and-valve assembly
 7 = Mounting device

7.9 Dismantling the barrel-and-valve assembly

Clamp mounting device KDEP 1066 in vise and insert barrel-and-valve assembly without spacer ring and O-ring (see picture b).

Unscrew delivery-valve holder. Remove compression spring, filler piece (if applicable), delivery valve and gasket.



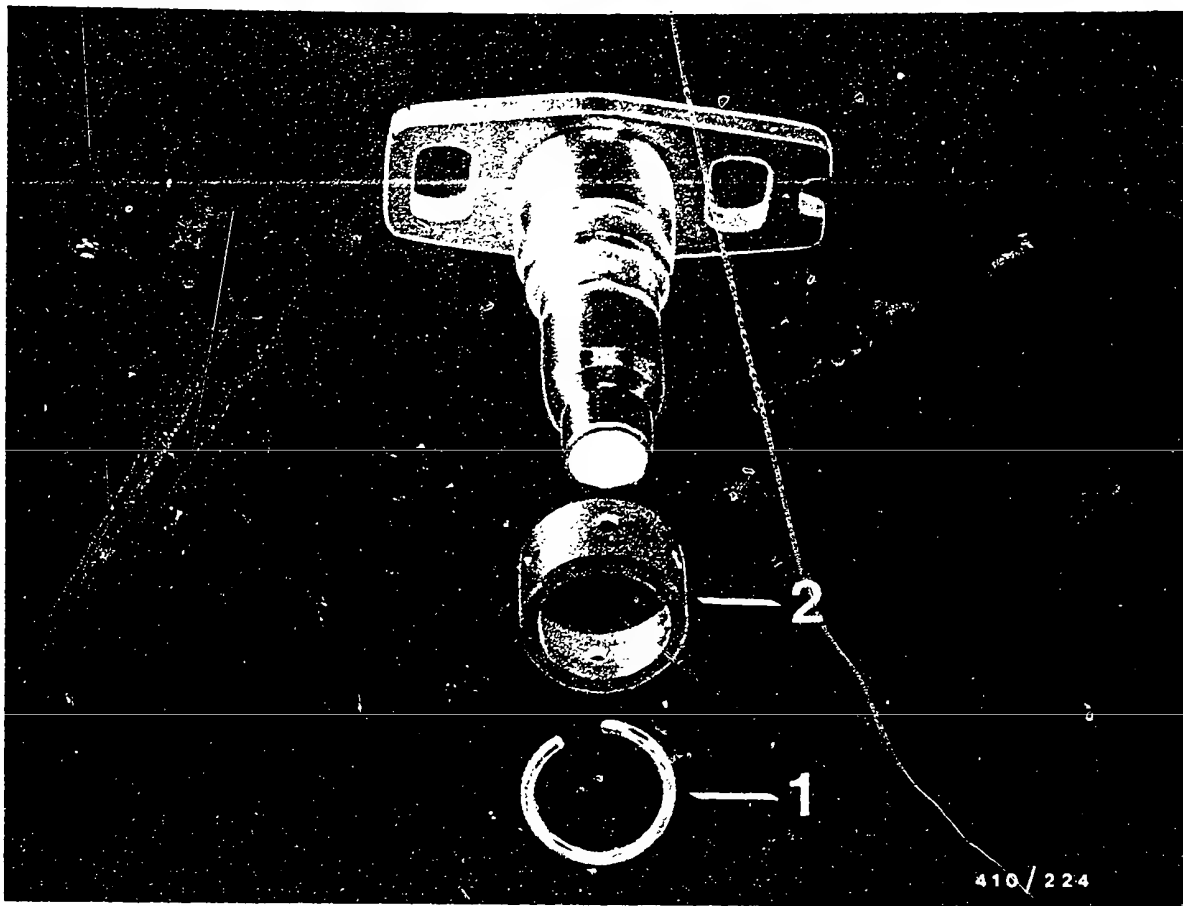

1 = Retainer

2 = Capsule

Remove retainer and capsule from plunger-and-barrel assembly.

C3

Dismantling the injection pump

PE(S) .. MW .., 0 413 ..



8. CLEANING THE COMPONENTS

Wash the components in low-inflammability, commercially available cleaning agent e.g. Chlorothene NU.

Then blow out with compressed air.

Observe the following safety regulations:

Decree on Working with Combustible Liquids (Vbf) issued by the Federal Ministry of Labor (BmA).

Safety Rules for Handling Chlorinated Hydrocarbons
for the Workshop ZH 1/222
for the Employee ZH 1/119

issued by the Central Association of German Employers' Liability Insurance Associations (Central Association for Accident Prevention and Industrial Medicine) Langwartweg 103, 5300 Bonn 5.

In countries outside the Federal Republic of Germany, observe the corresponding local regulations.

C4

Cleaning the components-Safety regulations

PE(S) .. MW .., 0 413 ..



9. CHECKING THE COMPONENTS

Worn or damaged components must be replaced.

Flat flange gaskets, radial-lip-type oil seals, O-rings, base plugs and copper seal rings must always be replaced.

C5

Checking the components

PE(S) .. MW .., 0 413 ..



Identification of pump service parts using abbreviated part number

The following explanatory remarks are intended to enable a comparison between the 10-digit part number and the number which is stamped or inscribed on the service part. This makes it possible to identify incorrectly installed components.

Identification is as follows:

Camshaft

1st and 6th to 10th digits of the part number, e.g.

<u>Part number</u>	<u>Identification</u>
1 416 126 302	126 302

Plunger-and-barrel assembly

1st and 5th to 10th digits of the part number, e.g.

<u>Part number</u>	<u>Identification</u>
1 418 325 010	1 325 010

The inscription on the plunger-and-barrel assembly is such that side 1 of the plunger control arm bears the 1st and 5th to 7th digits and side 2 of the plunger control arm bears the 8th to 10th digits of the part number.

C6

Checking the components

PE(S) .. MW .., 0 413 ..



Delivery valve

Identification is by means of 6 digits whereby the 1st digit represents a factory-internal code number and the remaining 5 digits are the 6th to the 10th digits of the part number, e.g.:

<u>Part number</u>	<u>Identification</u>
1 418 524 005	124 005

The inscription is as before on the valve stem.

The inscription is such that the first 3 digits are in the longitudinal groove and the other 3 digits in the longitudinal groove opposite.

In the case of delivery valves with a cylindrical stem, the inscription is either on the end face of the delivery valve or on the valve holder.

C7

Checking the components

PE(S) .. MW .., 0 413 ..



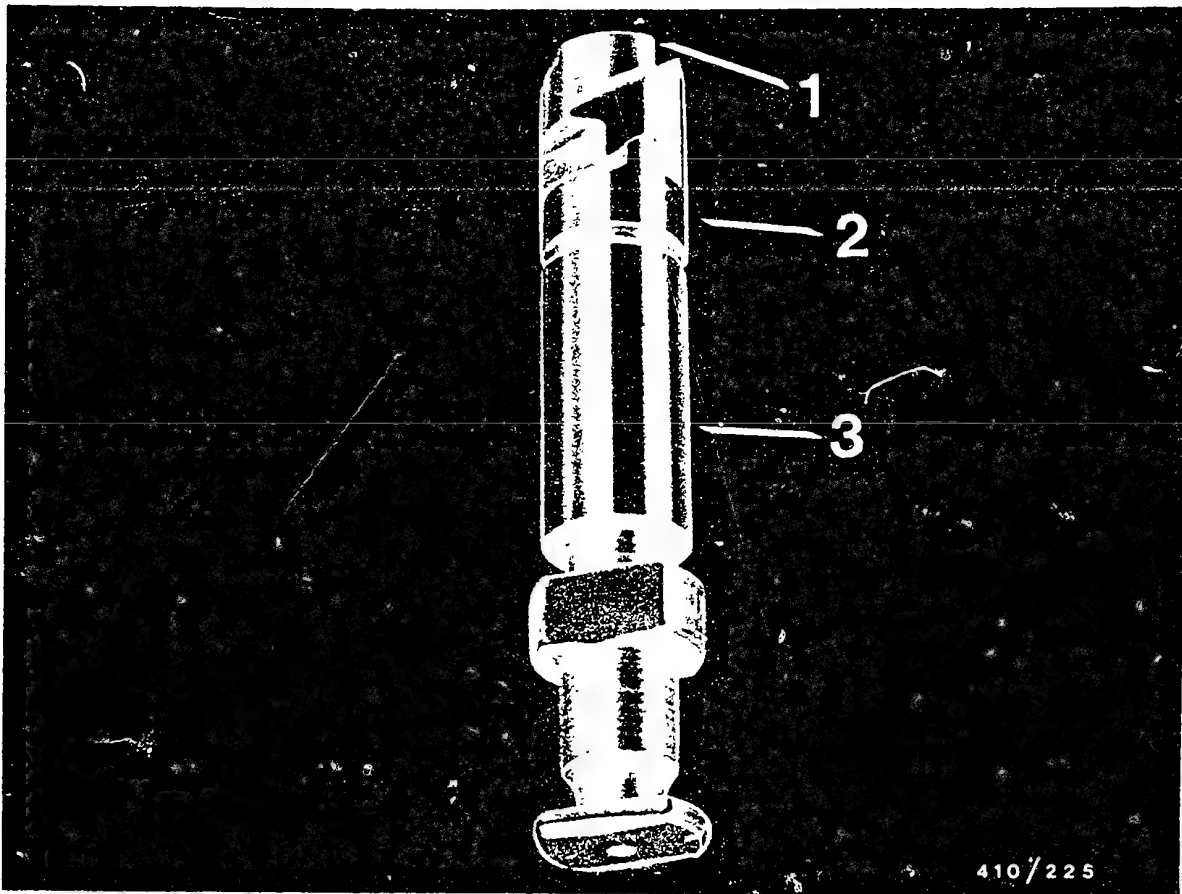

1 = Helixes
2 = Head region

3 = Bearing surface

Checking the plunger-and-barrel assemblies

Replace plunger-and-barrel assemblies if they exhibit the features listed below:

- Rounded helixes
- Dull areas in head region
- Wear marks on bearing surfaces
- Plungers sticking
(detectable by glide test)

Note: Before the glide test, wash plunger and barrel in calibrating oil. Hold pump plunger and barrel more or less vertical. The pump plunger must glide down under its own weight.

C8

Checking the components

PE(S) .. MW .., 0 413 ..



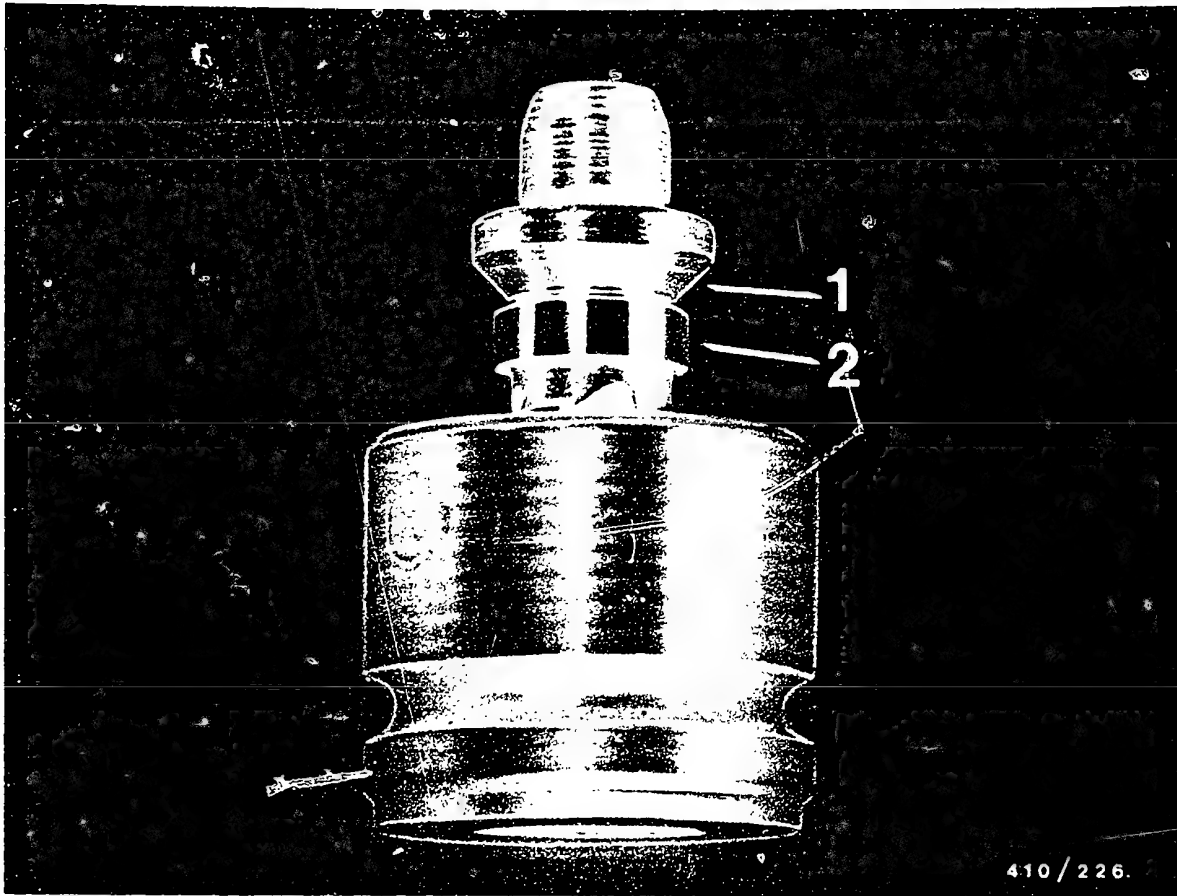

1 = Valve cone

2 = Retraction piston

Checking the delivery valves

The seating surface of the valve cone must not be pounded in or unevenly worn.

If the retraction piston is damaged or if the valve is sticking in the valve holder, replace delivery valve.

C9

Checking the components

PE(S) .. MW .., 0 413 ..



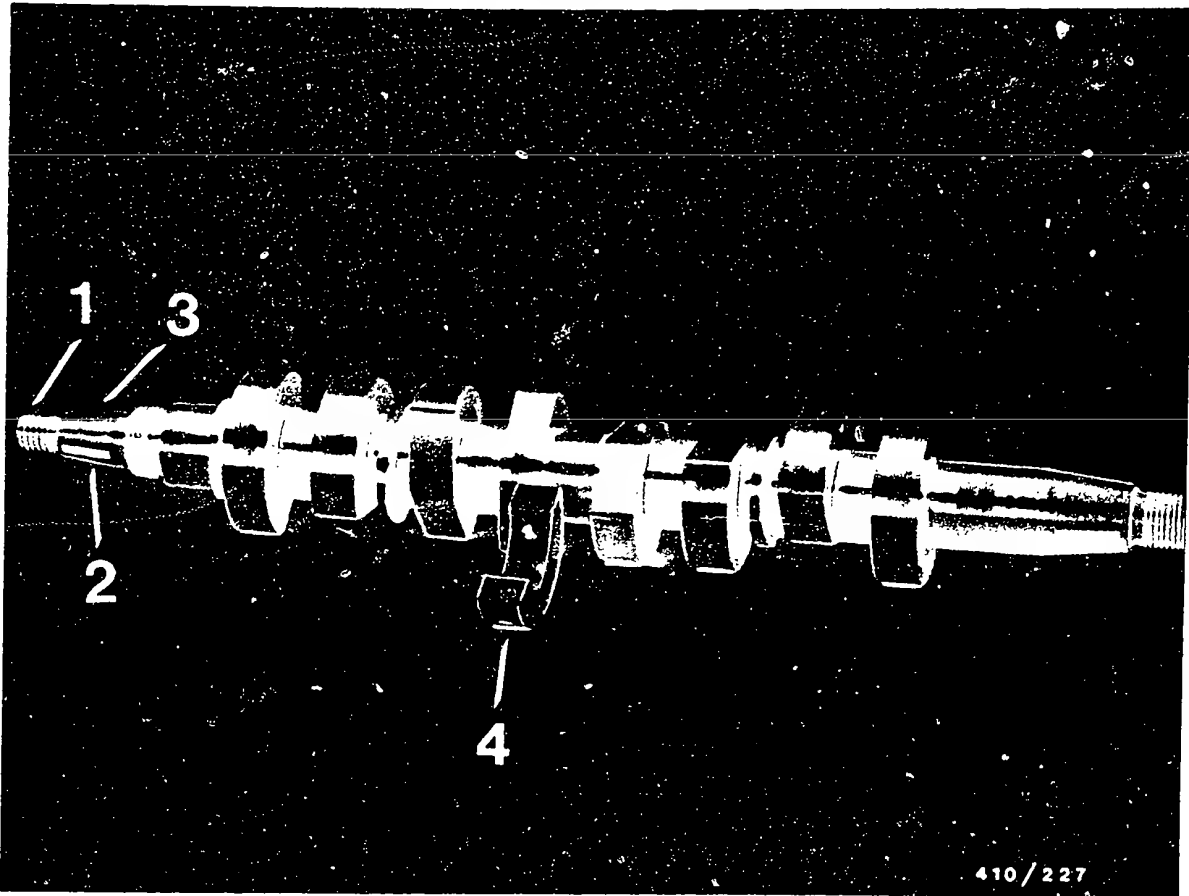

1 = Threaded stub
2 = Woodruff key groove

3 = Cone
4 = Intermediate bearing

Checking the camshaft

Visually examine the camshaft for:

- heavy wear marks on cams
- worn, damaged Woodruff key groove
- damage to threaded stub or cone.

If the above are applicable, replace camshaft.

Note:

Always replace camshaft bearings when carrying out repairs. Also replace intermediate bearings that exhibit score marks.



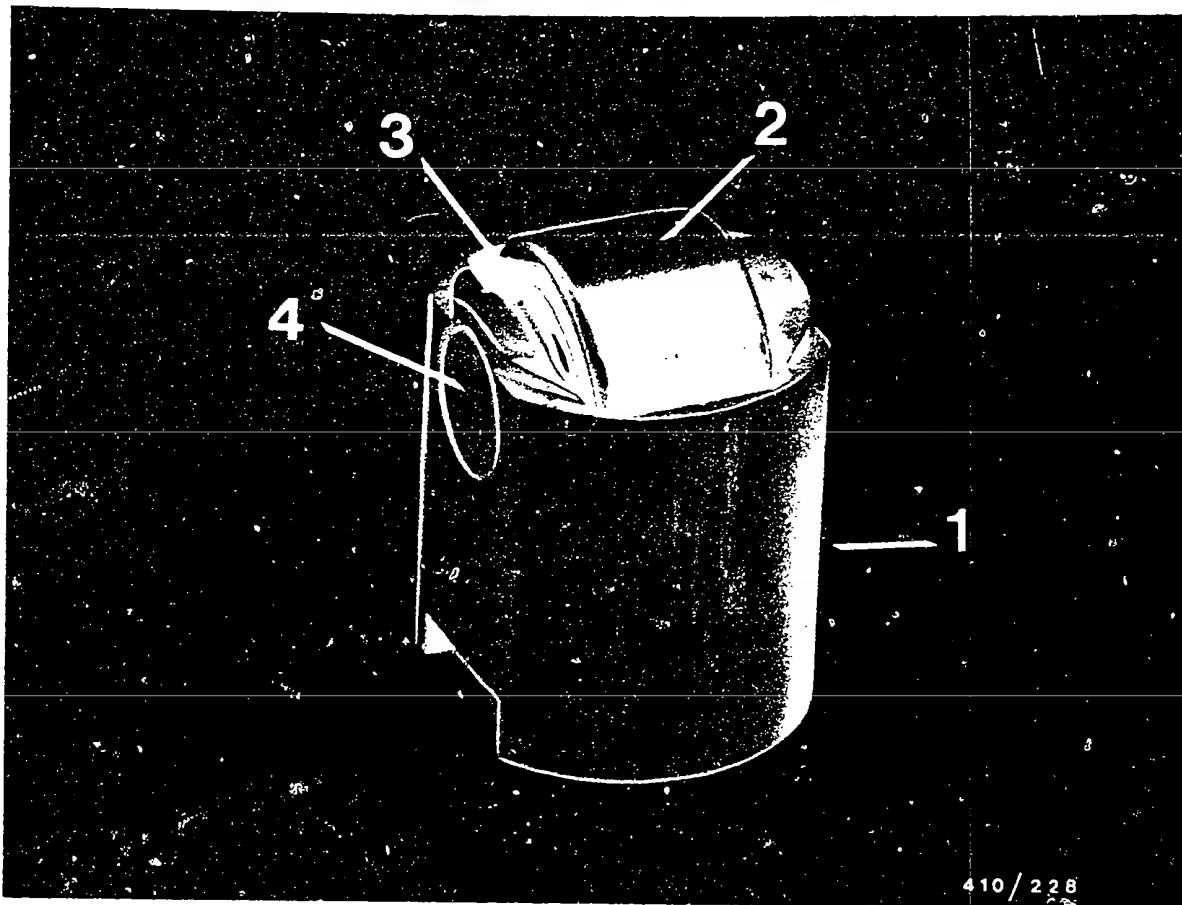

1 = Roller-tappet shell
2 = Roller

3 = Bearing bushing
4 = Bearing pin

Checking the roller tappets

Replace roller tappets if the following damage is applicable:

- heavy wear marks on roller-tappet shell
- heavy wear marks and/or discoloration on roller, bearing bushing and bearing pin.

Note:

If there are heavy wear marks on the roller-tappet shell, check the roller-tappet guide in the pump housing for score marks.

C11

Checking the components

PE(S) .. MW .., 0 413 ..



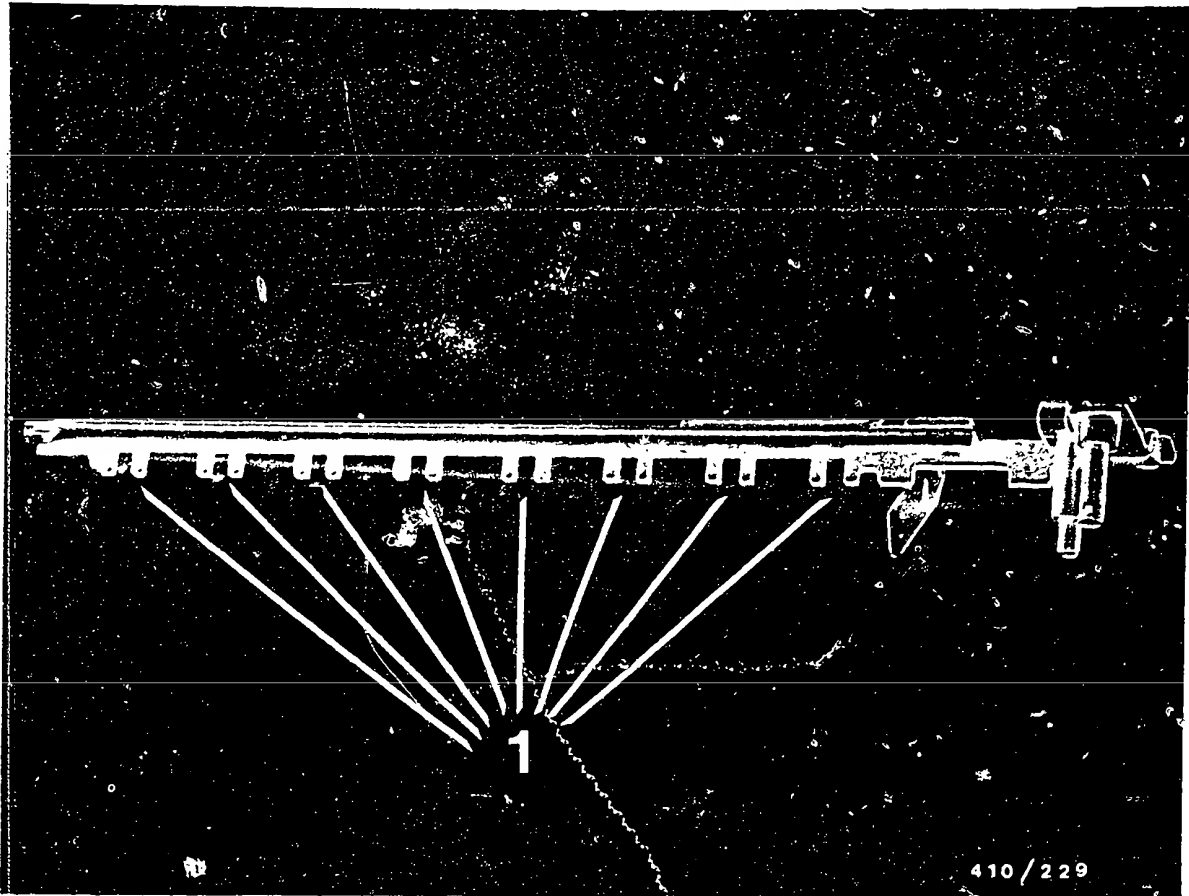

1 = Guide slits

Checking the control rod

Check the control rod for worn guide slits and for freedom of movement in housing.

C12

Checking the components

PE(S) .. MW .., 0 413 ..



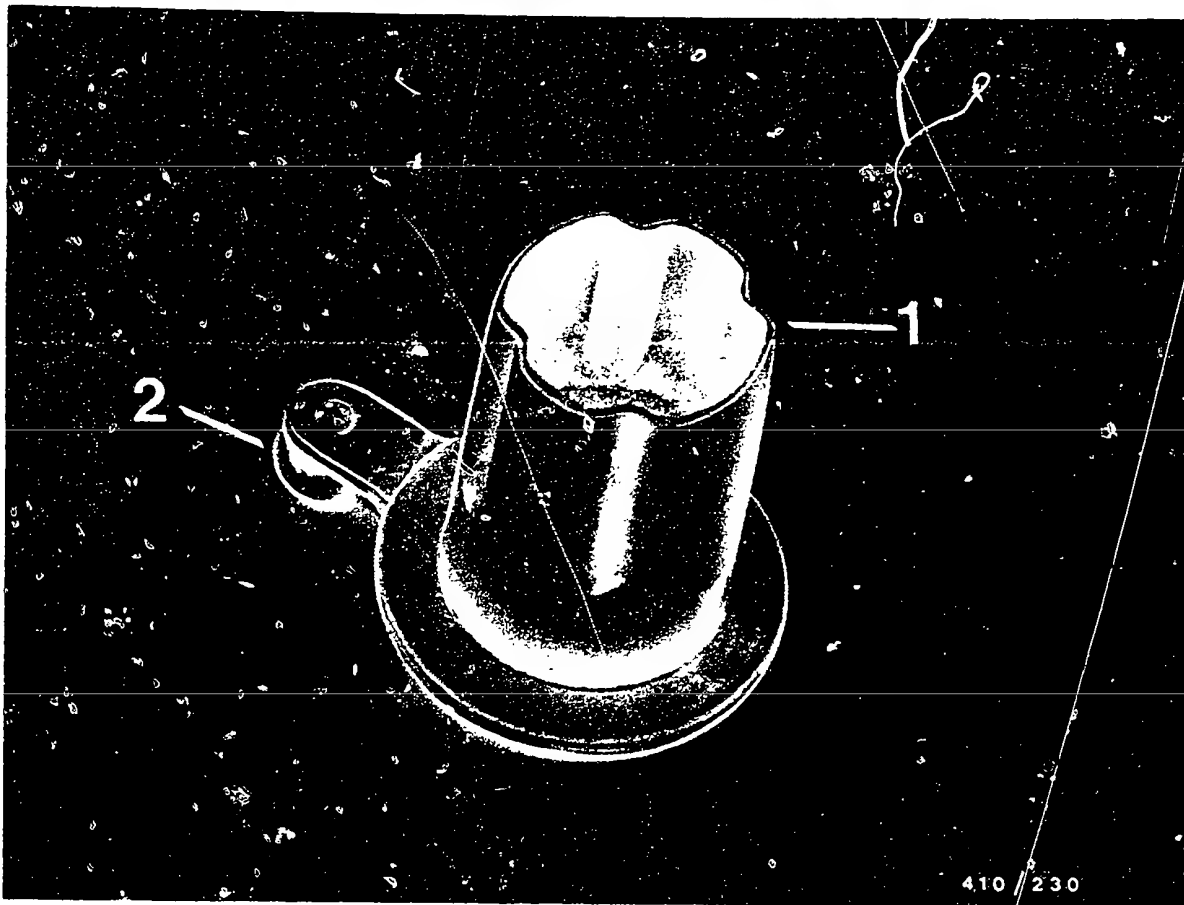

1 = Plunger control arm guide
2 = Driving ball

Checking the control sleeve

Replace control sleeve if the following damage is applicable:

- Deformation of plunger control arm guide
- Driving ball loose or its mounting bent

Note:

Install control sleeve as per service-parts list.

G13

Checking the components

PE(S) .. MW .., 0 413 ..



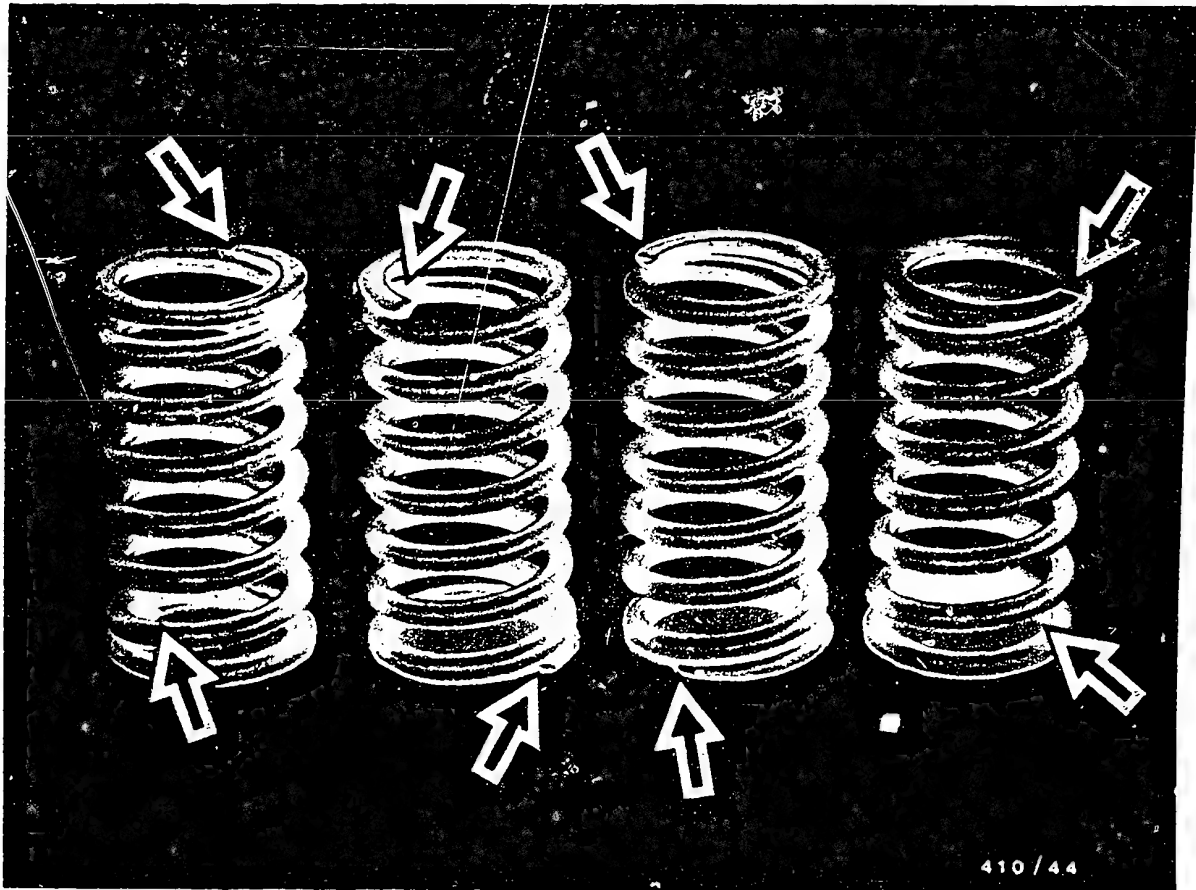

Plunger springs

Plunger springs that are corroded or whose surface is damaged must be replaced due to the danger of breakage.

Check in particular the seating surface of the first turn (see picture, arrows).

C14

Checking the components

PE(S) .. MW .., 0 413 ..



Checking the pump housing

- Check housing for cracks and other external damage.

Check the following in particular:

- Threads on stay bolts and threaded holes.
- Score marks on roller-tappet guides.
- Freedom of movement of control rod in its guide.
- Cavitation in suction gallery.
- Security of spacer ring in pump housing.
- Damage to control-rod guide pin.

Note:

Replacement of the suction-gallery closure caps is not allowable because security and absolute freedom from leaks of the closure caps is not guaranteed.

If leaking is detected at the suction-gallery closure caps, replace pump housing.

C15

Checking the components

PE(S) .. MW .., 0 413 ..



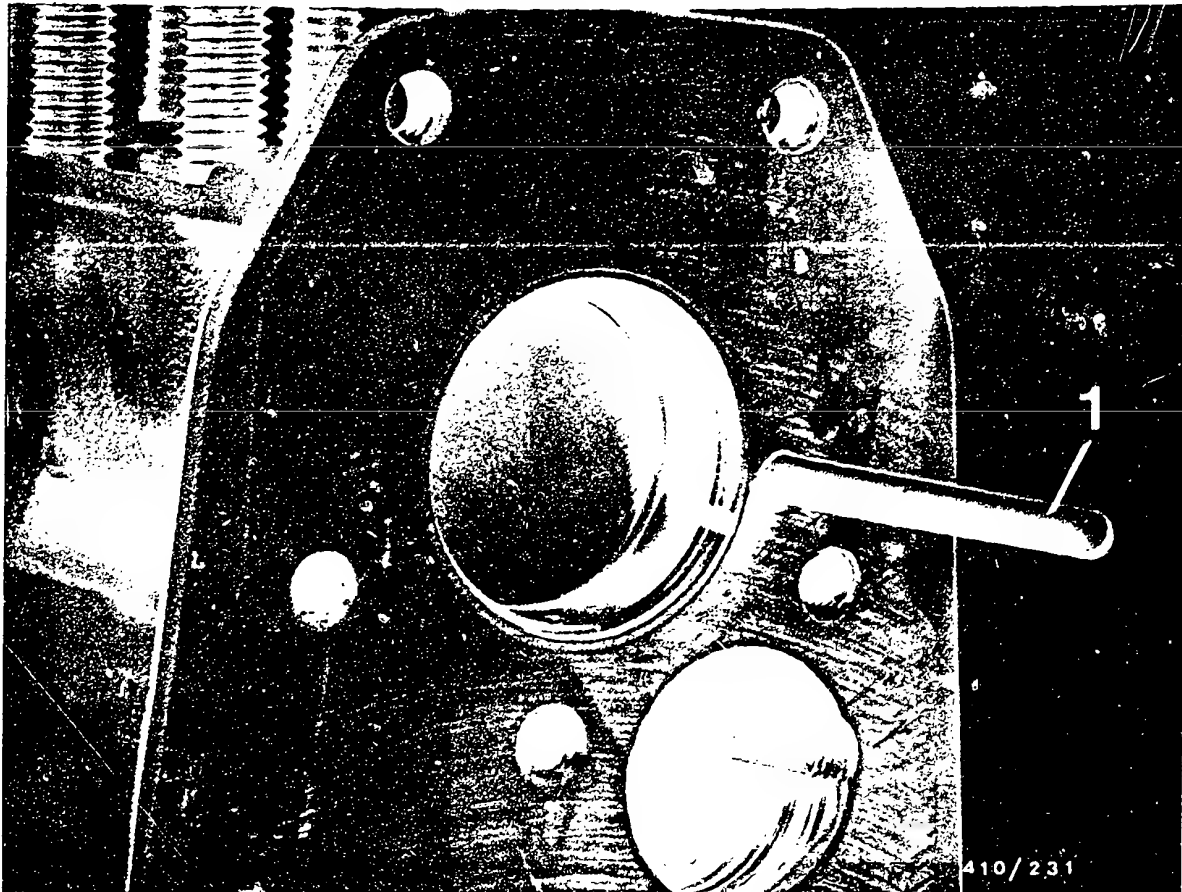

1 = Control-rod guide pin

10. REPAIRING THE PUMP HOUSING

10.1 Pressing in the control-rod guide pin

If, when checking the components, the control-rod guide pin was found to be damaged or broken, it is necessary to install a new guide pin.

C16

Repairing the pump housing

PE(S) .. MW .., 0 413 ..





10.2 Replacing the control-rod mounting capsule

-PE(S).. MW.. S1 with 8 mm stroke

Using 20 mm diameter mandrel, press out the old guide-rod mounting capsule in the direction of the drive end.

Clean the bore (degrease).

Coat new control-rod mounting capsule with Loctite 601. Align the capsule in the correct installation position (see picture).

Provisionally install control rod in housing and check for freedom of movement.

Press in control-rod mounting capsule as far as it will go with press-in mandrel KDEP 1590.

C18

Repairing the pump housing

PE(S) .. MW .., 0 413 ..



Note:

Loctite 601 takes approx 3 hours to set at 20° C.

When pressing in the control-rod mounting capsule, make sure that the control-rod guide pin is not damaged.

C19

Repairing the pump housing

PE(S) .. MW .., 0 413 ..



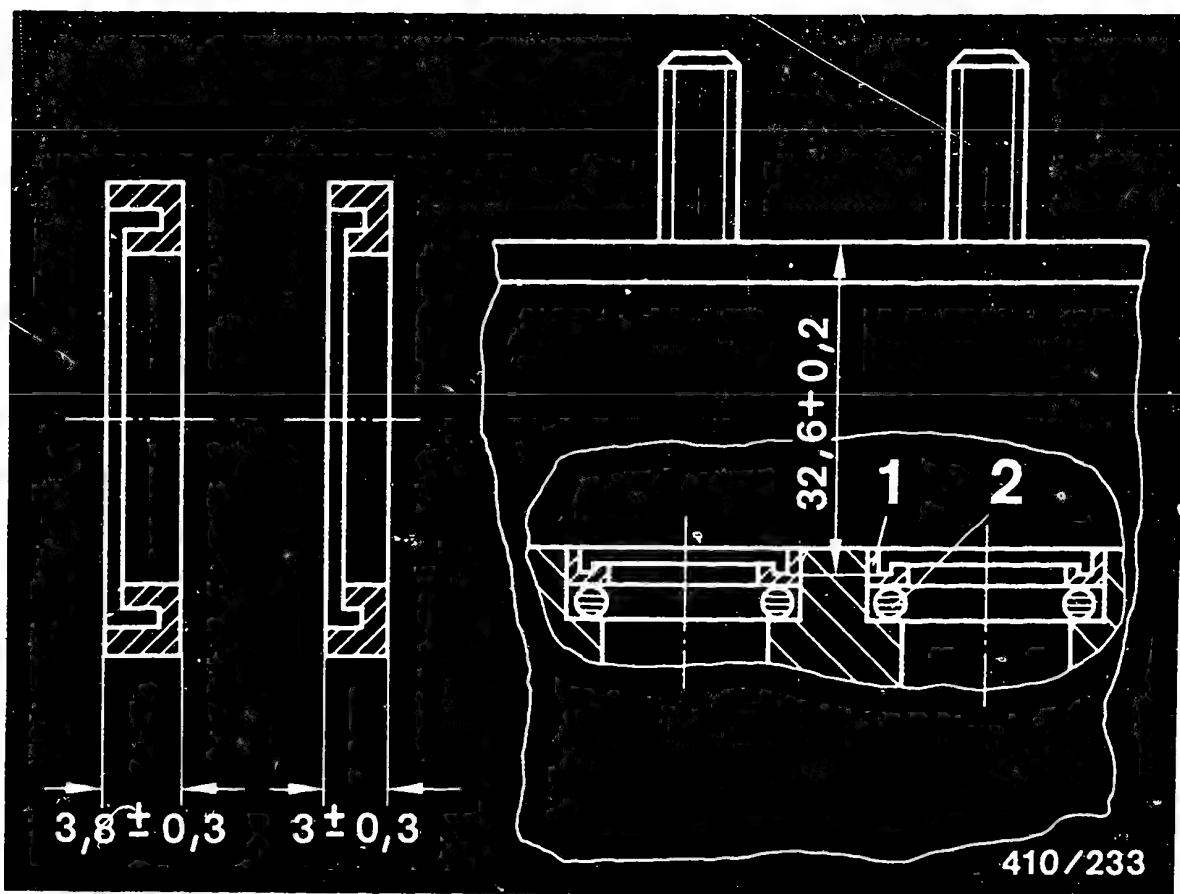

1 = Spacer ring

2 = O-ring

Installing the spacer ring and O-ring (bottom suction gallery seal in housing)

Injection pumps up to FD 621:

Insert O-ring (thickness of cord 0.25 mm) in pump housing. Insert new spacer ring (3.8 ± 0.3 mm thick, see picture) in pump housing with U-shaped opening to the top, and press in as far as it will go using press-in mandrel KDEP 1592 under arbor press.

C20

Repairing the pump housing

PE(S) . . . MW . . . 0 413 . . .



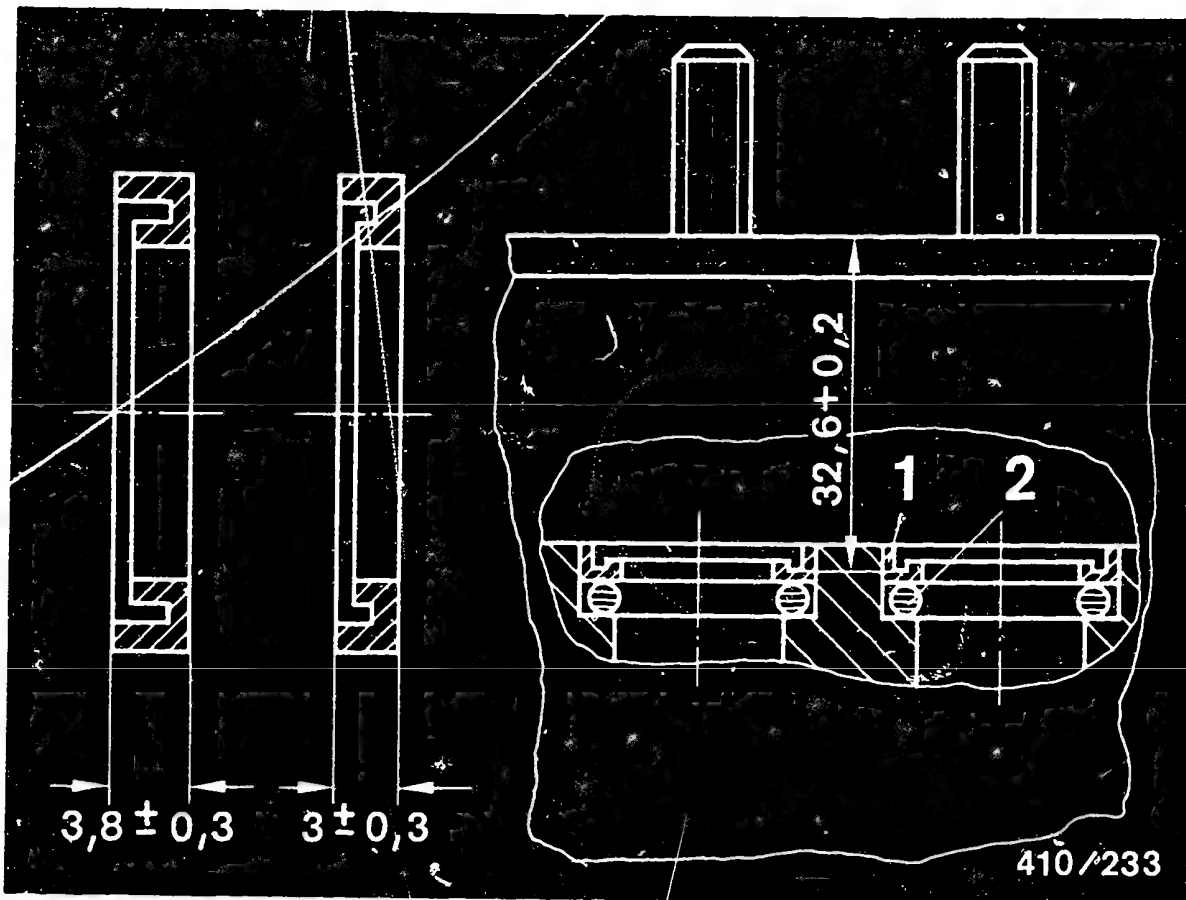

1 = Spacer ring

2 = O-ring

Injection pumps as of FD 621:

Insert O-ring (thickness of cord 0.3 mm) in pump housing. Insert new spacer ring (3.0 ± 0.3 mm thick, see picture) in pump housing with U-shaped opening to the top, and, using press-in mandrel KDEP 1592, press in so that the collar of the press-in mandrel rests on the pump housing. Press-in depth 32.6 ± 0.2 mm (see picture).

C21

Repairing the pump housing

PE(S) . . MW . . . 0 413 . .



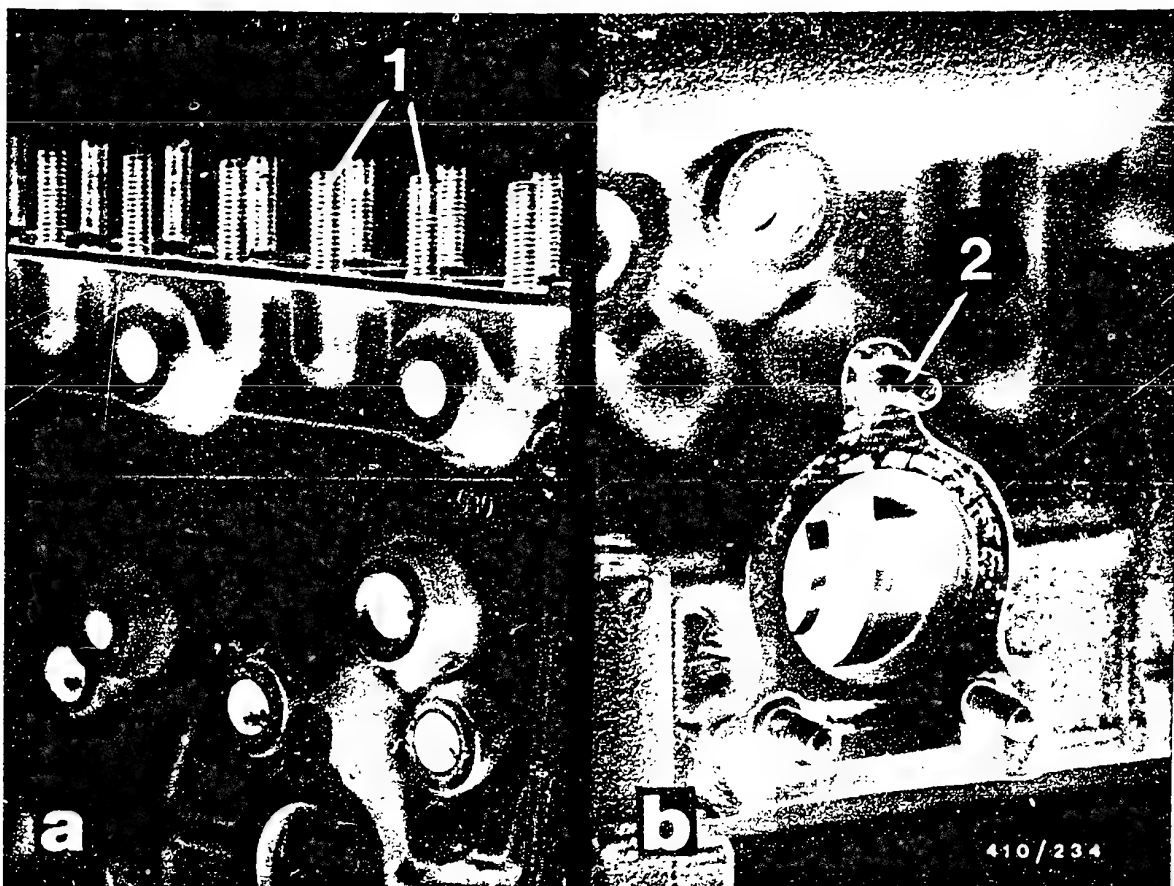

- 1 = Threaded pin of barrel-and-valve assemblies
2 = Threaded pin of supply pump

10.5 Replacing the threaded pins

Glue in threaded pins for mounting of barrel-and-valve assemblies with Loctite CVX.

Glue in threaded pins for mounting of supply pump with Loctite 601.

Note:

Loctite CVX takes min. 8 hours to set at 20°C and min. 0.5 hours with activator "T".



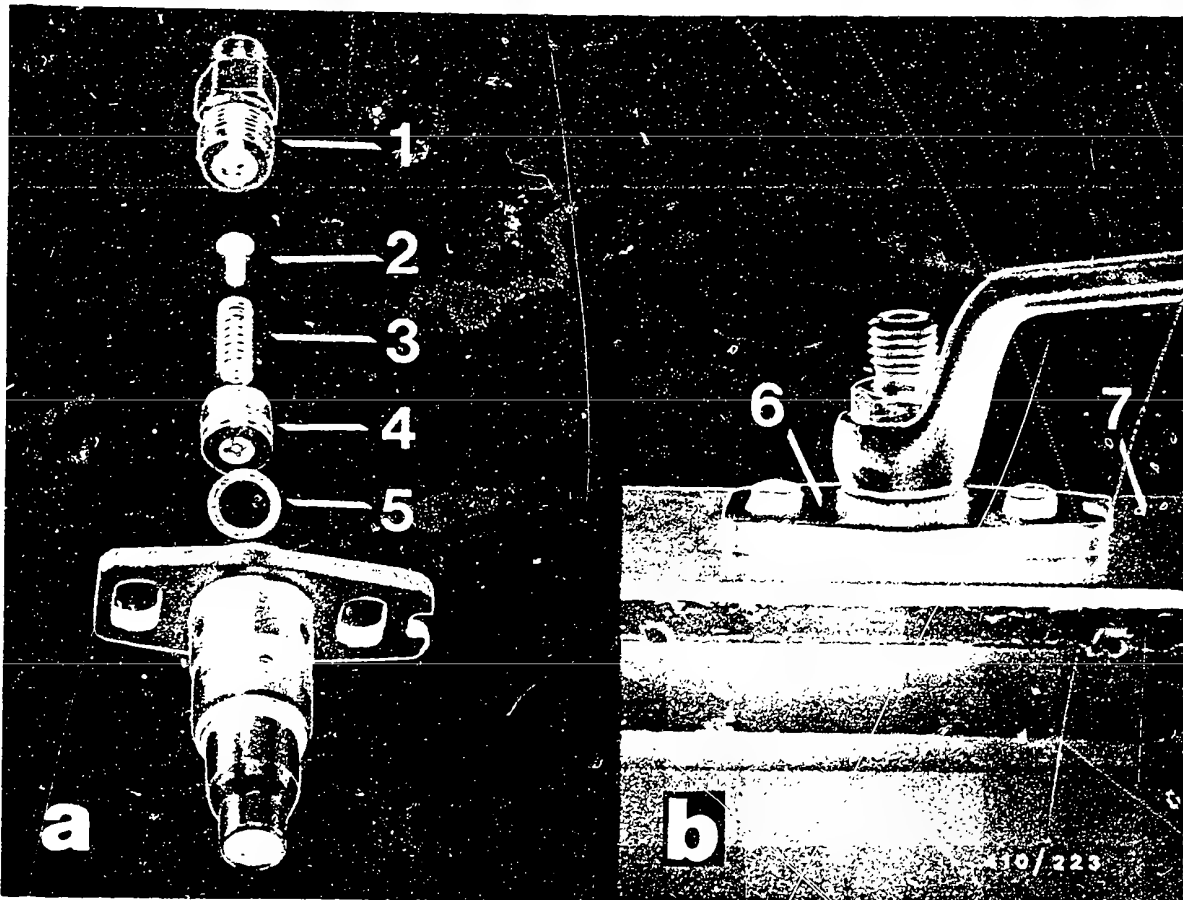

- 1 = Delivery-valve holder
- 2 = Filler piece
- 3 = Compression spring
- 4 = Delivery valve

- 5 = Gasket
- 6 = Barrel-and-valve assembly
- 7 = Mounting device

11. ASSEMBLING THE BARREL-AND-VALVE ASSEMBLY

Clamp mounting device KDEP 1066 in vise.

Insert gasket, delivery valve, compression spring and filler piece (if applicable) in plunger-and-barrel assembly.

Tighten delivery-valve holder to 50 - 60 Nm.

Note:

Gasket must be installed between plunger-and-barrel assembly and delivery valve.



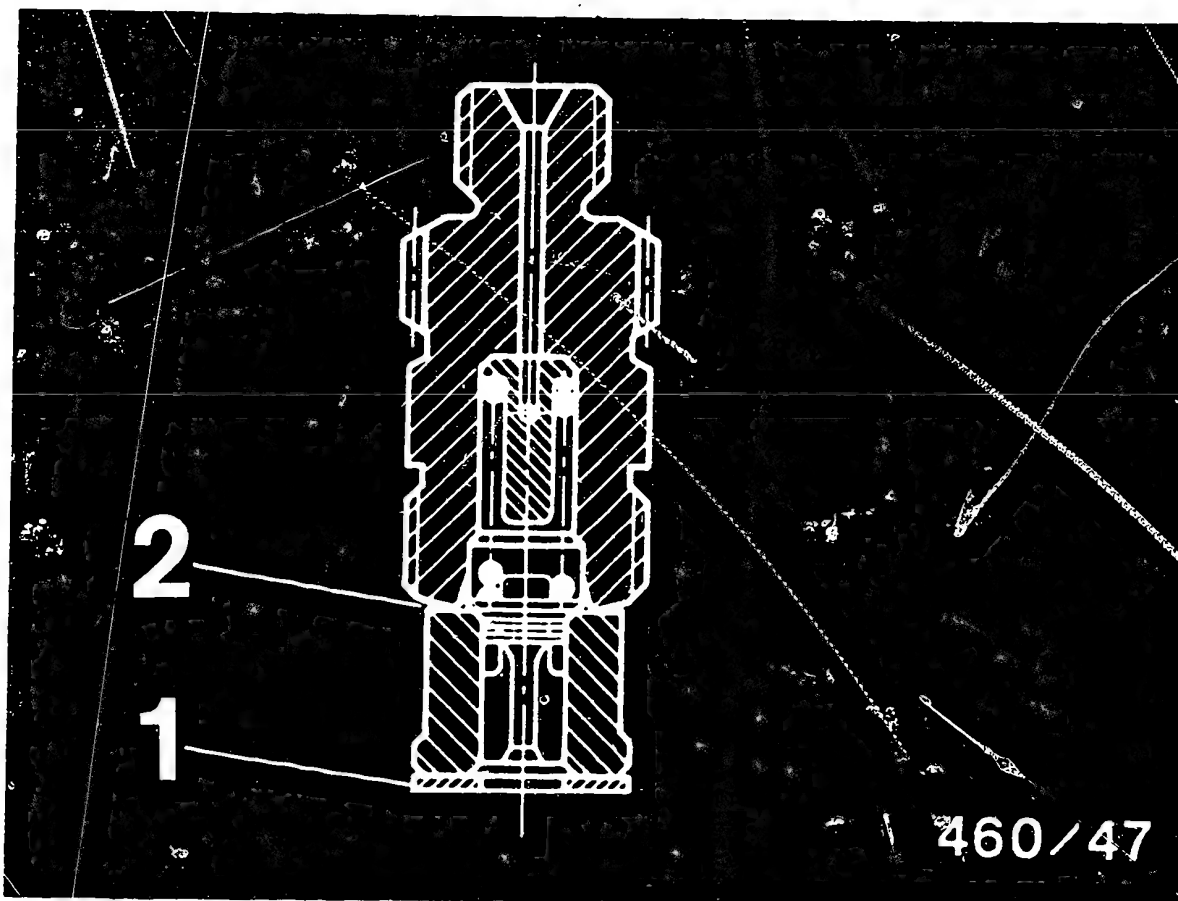

- 1 = Bronze gasket
2 = Delivery-valve biting edge

Note:

Whenever the delivery-valve holder has been loosened (e.g. when replacing the valve), replace the bronze gasket between valve holder and barrel.

Visually examine the gasket and delivery-valve biting edge for surface defects. In the case of scoring and scratches, replace the parts concerned.

Briskly tighten the delivery-valve holder to a torque of 50 - 60 Nm.

Do not loosen and re-tighten.

C24

Assembling barrel-and-valve assys

PE(S).. MW.., 0 413 ..



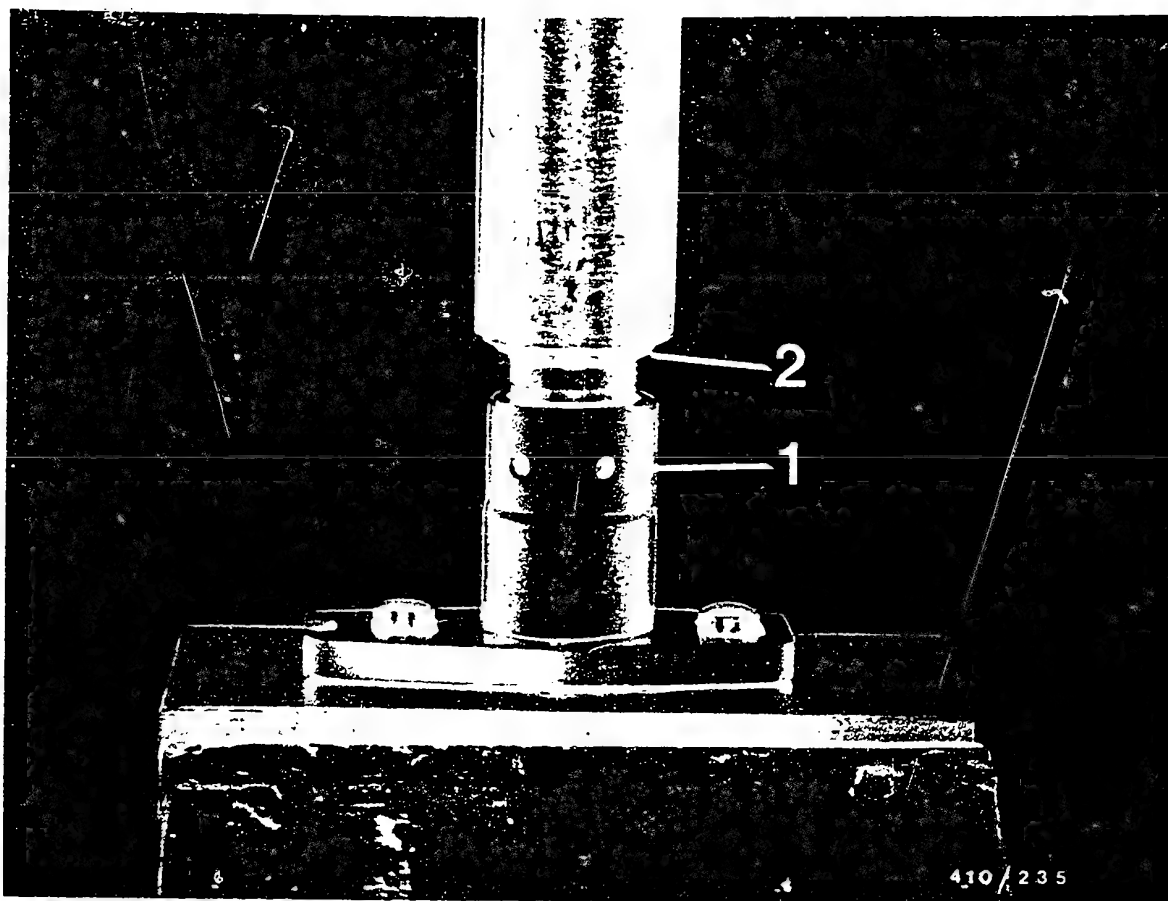

1 = Capsule

2 = Retainer

Take barrel-and-valve assembly out of mounting device KDEP 1066.

Insert barrel-and-valve assembly in mounting device with delivery-valve holder at the bottom.

Slide capsule onto pump barrel.

Slide taper sleeve from mounting sleeve set KDEP 1593 onto pump barrel.

Slide retainer onto taper sleeve and press retainer as far as the groove with a forcer.

Remove mounting sleeve set.

D1

Assembling the barrel-and-valve assembly
PE(S) .. MW .., 0 413 ..



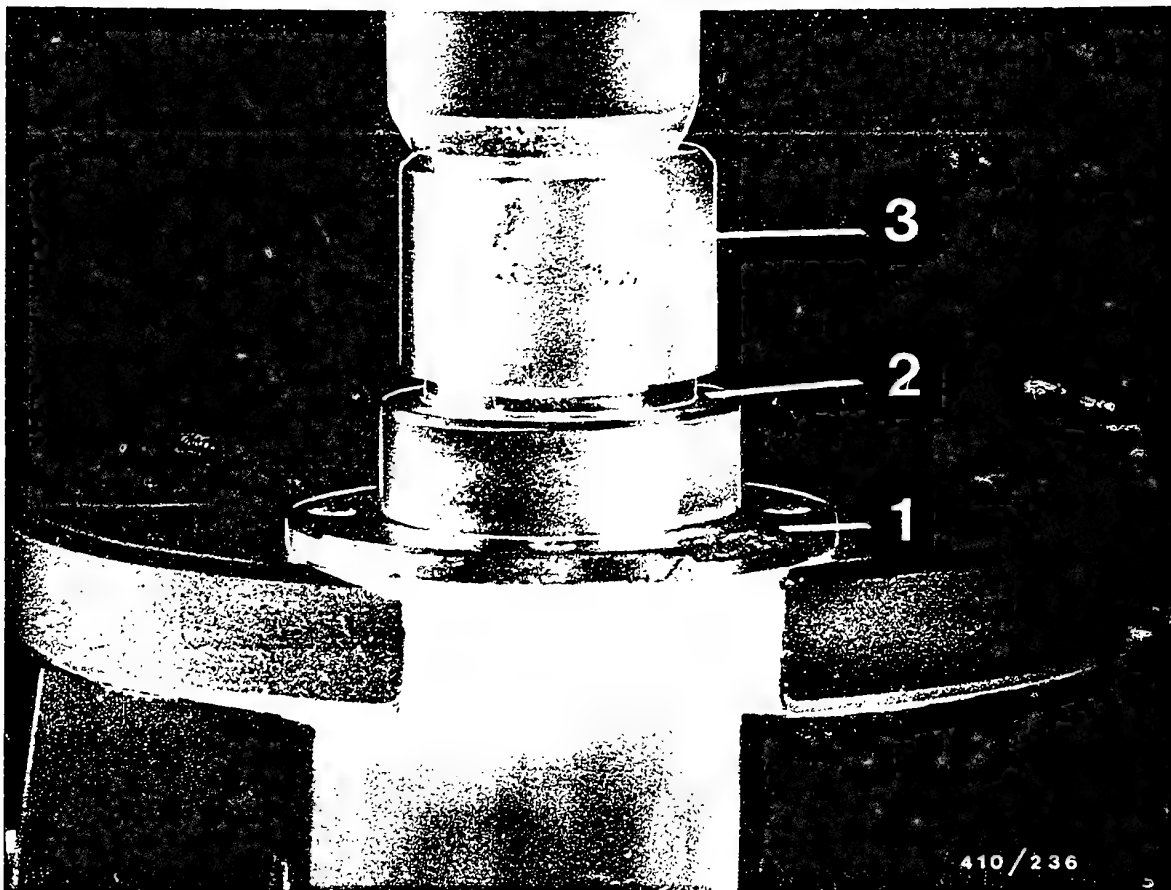

1 = Bearing end plate
2 = Needle-roller bearing

3 = Press-in tool

12. REPLACING THE CAMSHAFT BEARING AT THE DRIVE END

Using press-in tool KDEP 1059, press in needle-roller bearing of 32 mm outside diameter so that it is flush.

Using press-in tool KDEP 1059 (recess in press-in tool pointing toward bearing), press needle-roller bearing of 37 mm outside diameter into bearing end plate until tool rests on bearing end plate.

Note:

Needle-roller bearing projects slightly corresponding to the recess in the tool.

D2

Replacing the camshaft bearing

PE(S) .. MW .., 0 413 ..



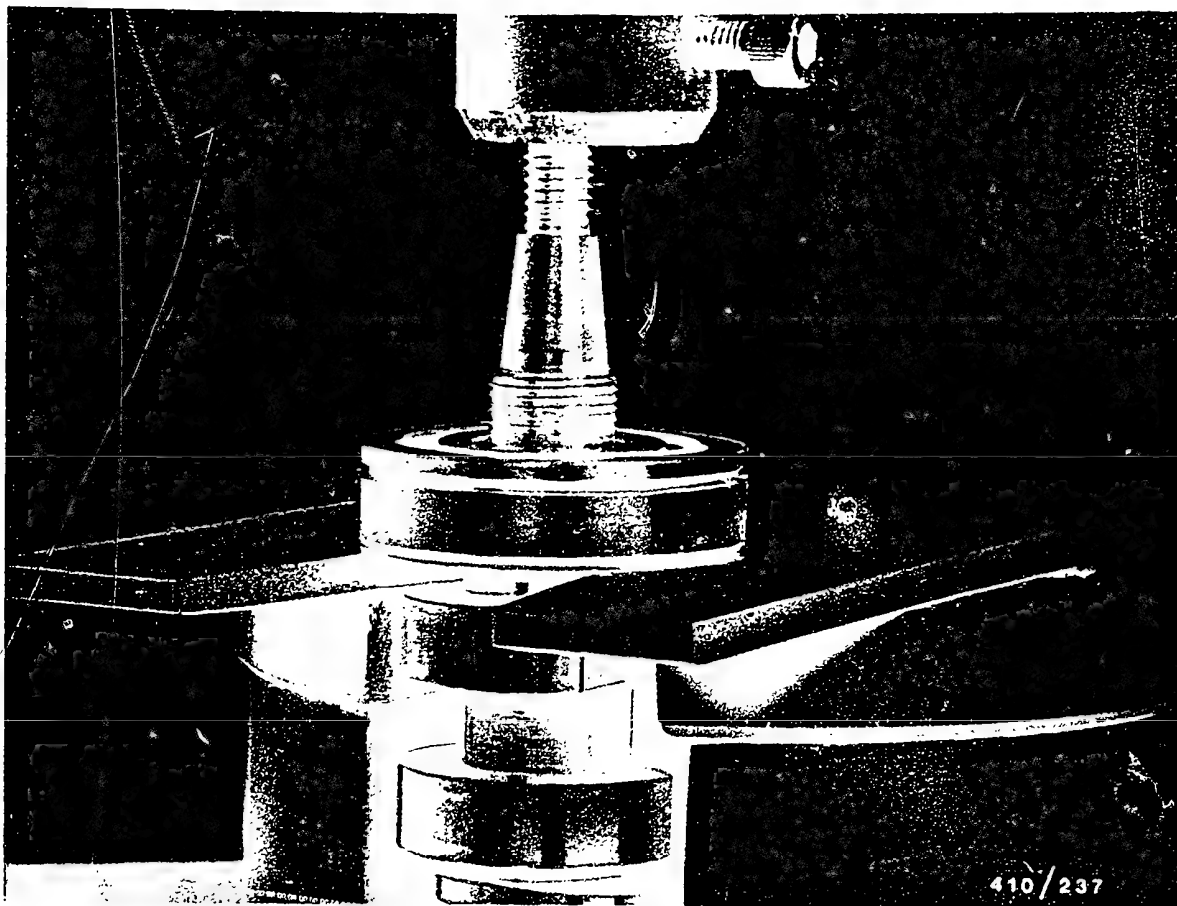

Using forcing-off plate KDEP 1580, force deep-groove ball bearing from camshaft (see picture).

Note:

The forcing-off plate is suitable for all camshaft diameters.-

Slide the camshaft into the recess until the bearing collar rests on both sides (see picture).

D3

Replacing the camshaft bearing

PE(S) .. MW .., 0 413 ..



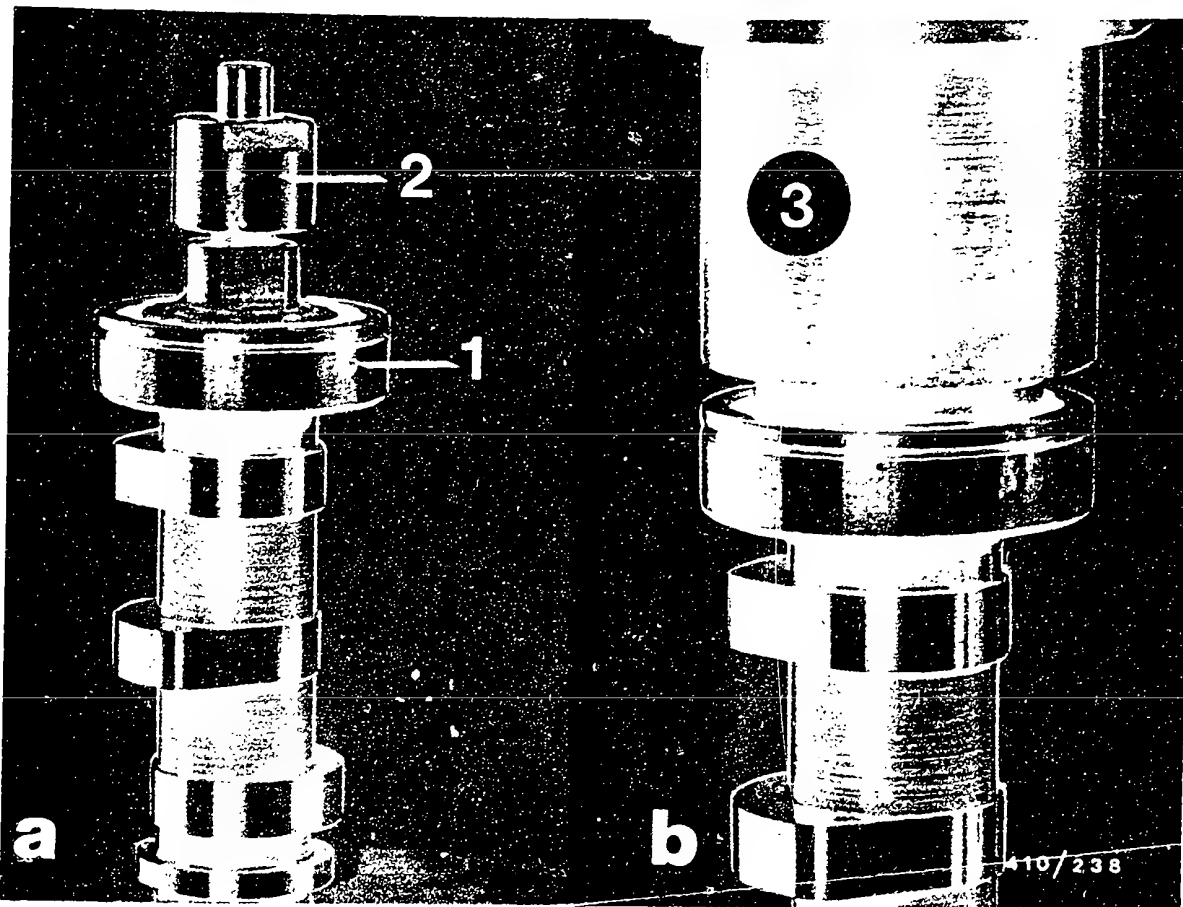

- 1 = Deep-groove ball bearing 3 = Press-in sleeve
 2 = Guide bushing

12.1 Pressing in the deep-groove ball bearing at the governor end
 PE(S).. MW.. (8 mm stroke)

Place new deep-groove ball bearing on camshaft stub (at governor end).

Screw guide sleeve (contained in parts set of press-in tool KDEP 1060) onto camshaft.

Using press-in sleeve KDEP 1060, press on deep-groove ball bearing under an arbor press.

Note: Press only on the inner race.



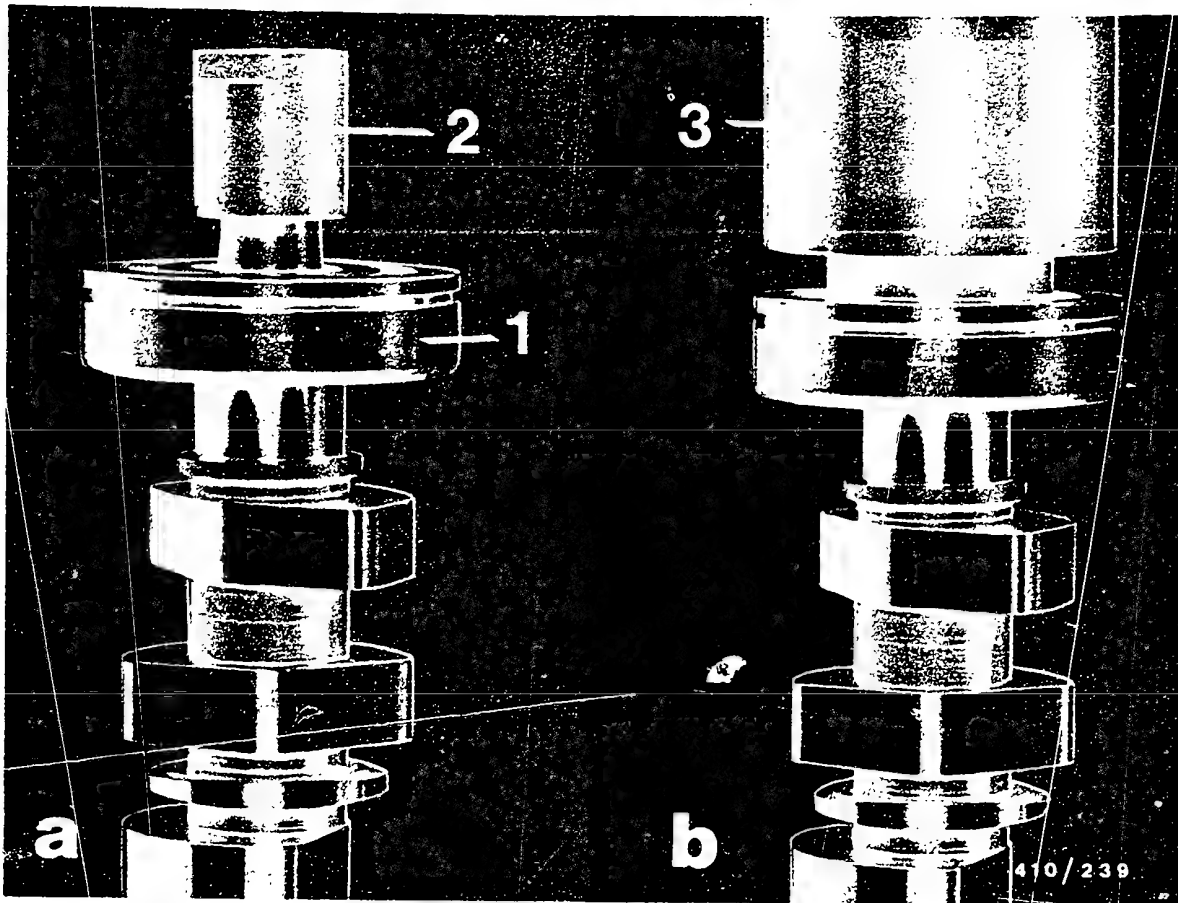

1 = Deep-groove ball bearing
2 = Guide bushing

3 = Press-in sleeve

12.2 Pressing in the deep-groove ball bearing at the governor end

PE(S).. MW.. S 1000 (10 mm stroke)

Place deep-groove ball bearing on camshaft stub (at governor end).

Screw guide sleeve (contained in parts set of press-in tool KDEP 1069) onto camshaft.

Using press-in sleeve, press on deep-groove ball bearing under an arbor press.

Note: Press only on the inner race.

D5

Replacing the camshaft bearing

PE(S) .. MW .., 0 413 ..



13. ASSEMBLING THE INJECTION PUMP

Clamp injection pump housing according to type of mounting.

In the following operations, use only components which have been cleaned and which are not worn or damaged.

Prior to assembly, wet all moving parts with calibrating oil.

Rub tallow into O-rings.

D6

Assembling the injection pump

PE(S) .. MW .., 0 413 ..



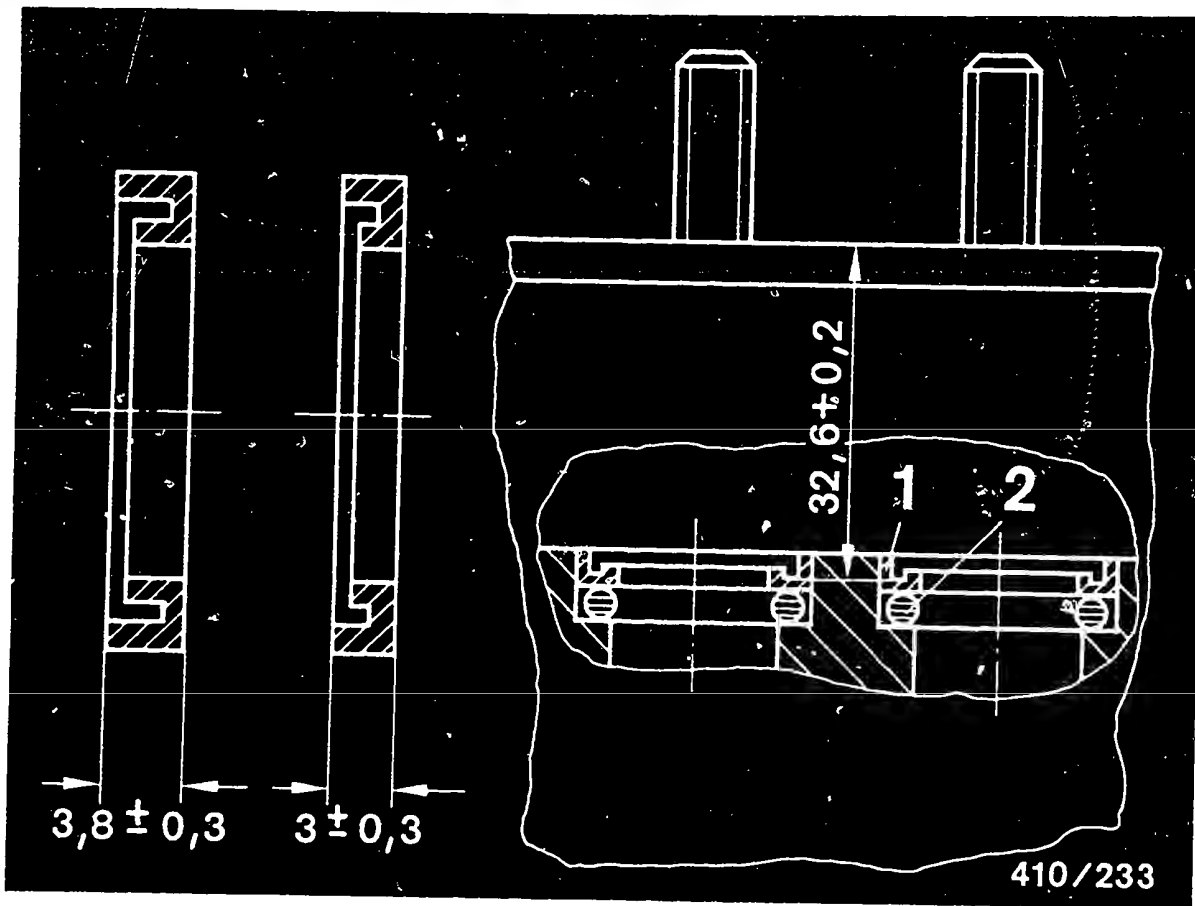

1 = Spacer ring

2 = O-ring

Installing the spacer ring and O-ring (bottom suction gallery seal in housing)

Injection pumps up to FD 621:

Insert O-ring (thickness of cord 0.25 mm) in pump housing. Insert new spacer ring (3.8 ± 0.3 mm thick, see picture) in pump housing with U-shaped opening to the top, and press in as far as it will go using press-in mandrel KDEP 1592 under arbor press.

D7

Assembling the injection pump

PE(S) .. MW .., 0 413 ..



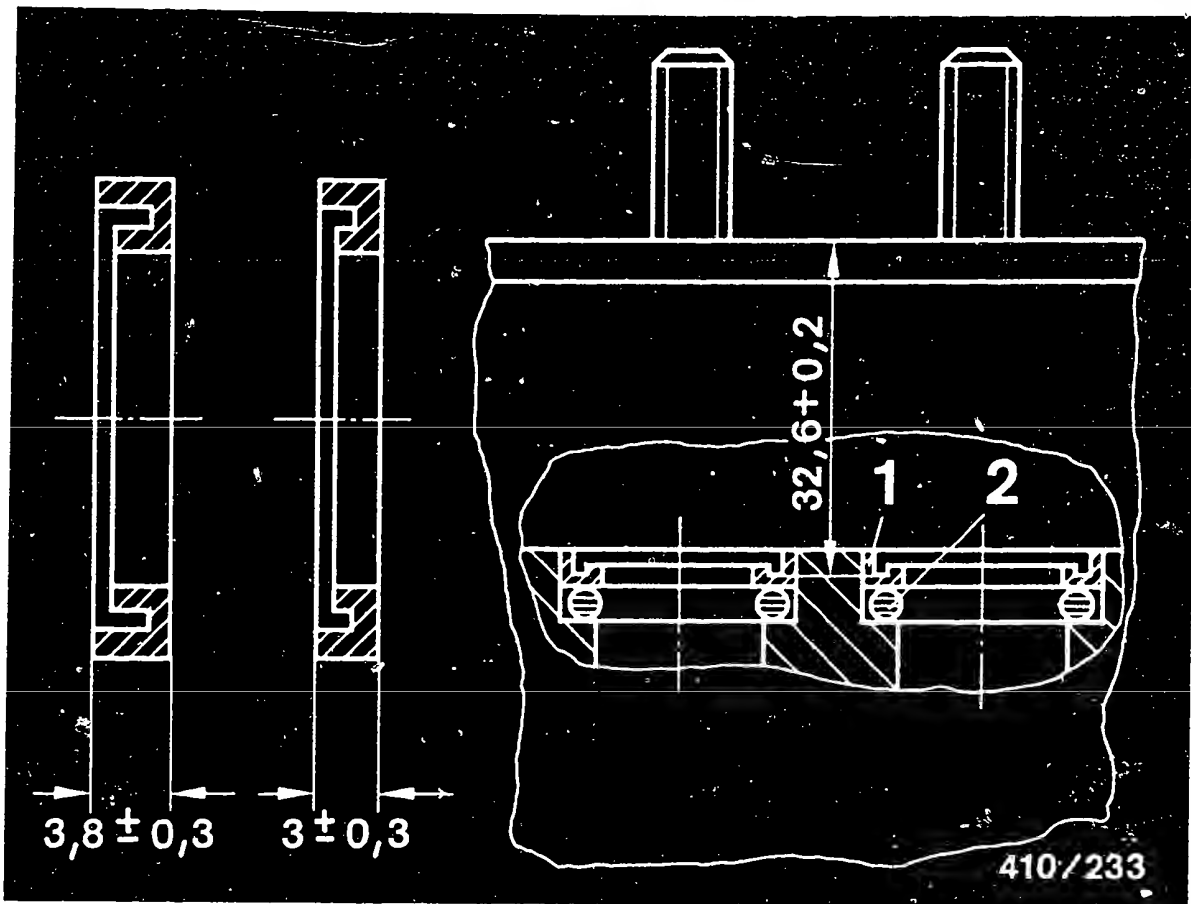

1 = Spacer ring

2 = O-ring

Injection pumps as of FD 621:

Insert O-ring (thickness of cord 0.3 mm) in pump housing. Insert new spacer ring (3.0 ± 0.3 mm thick, see picture) in pump housing with U-shaped opening to the top, and, using press-in mandrel KDEP 1592, press in so that the collar of the press-in mandrel rests on the pump housing. Press-in depth 32.6 ± 0.2 mm (see picture).

D8

Assembling the injection pump

PE(S) .. MW .., 0 413 ..



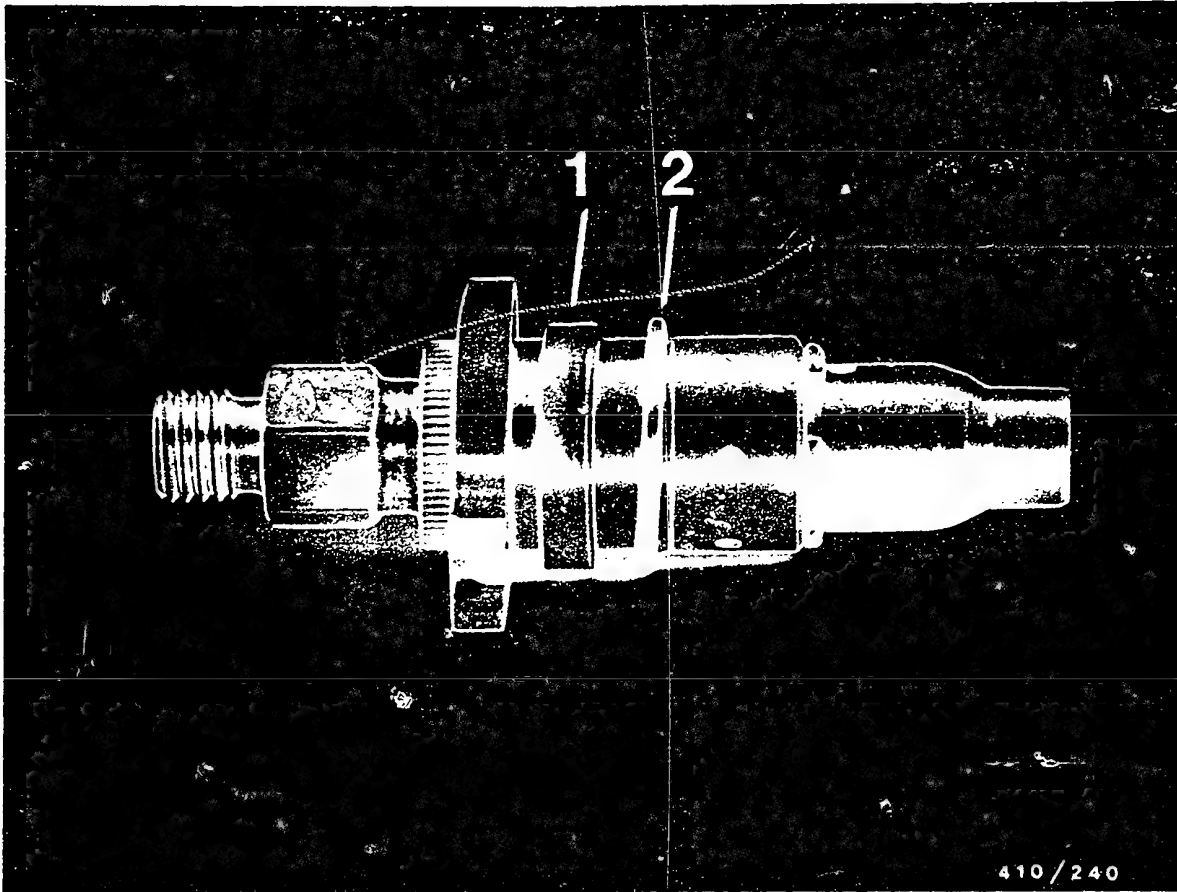

1 = Spacer ring

2 = O-ring

Slide spacer ring and O-ring onto barrel-and-valve assembly (see picture).

Pay attention to installation position: Open side of spacer ring pointing toward flange.

D9

Assembling the injection pump

PE(S) .. MW .., 0 413 ..



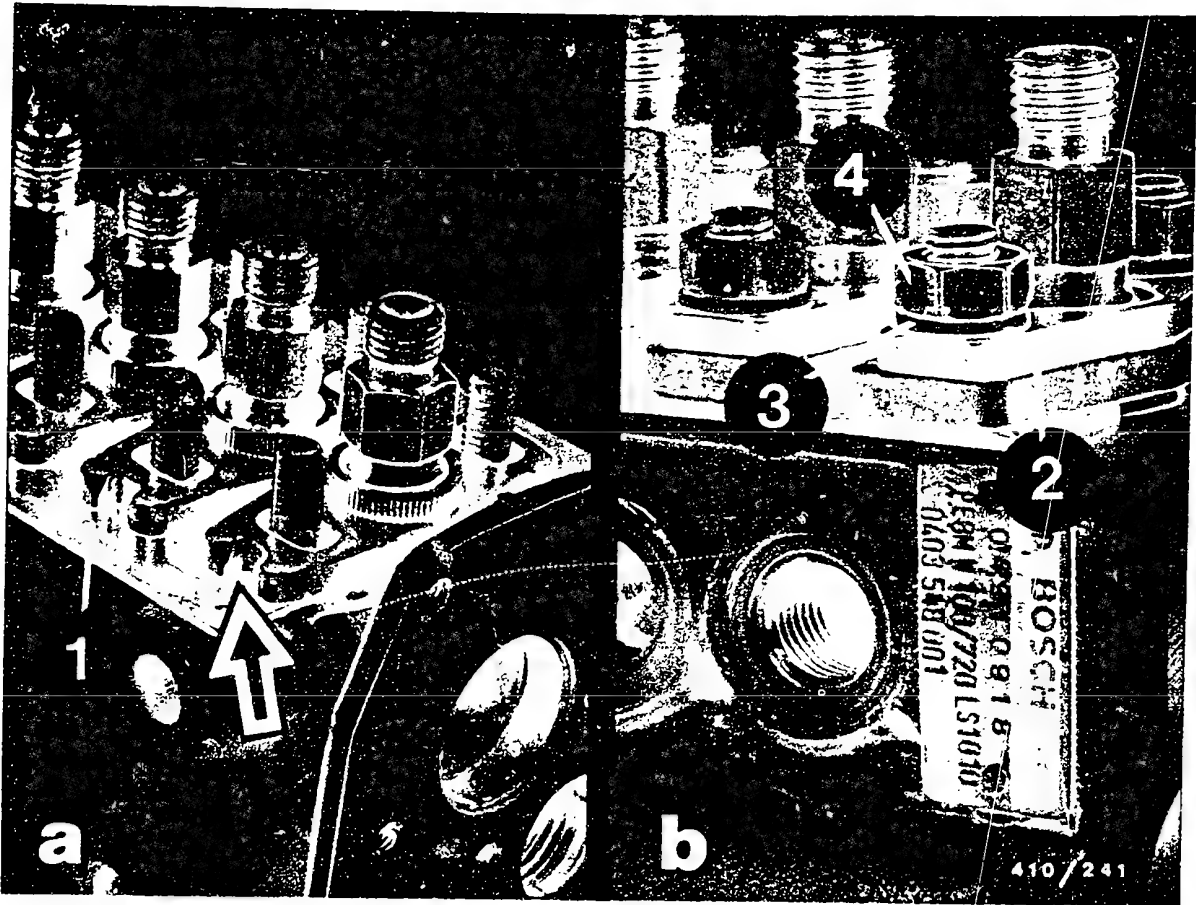

1 = Spacer plate
2 = Support plate

3 = Spring lock washer
4 = Hexagon nut

13.1 Installing the barrel-and-valve assembly

Install barrel-and-valve assembly in pump housing so that the adjusting groove on the assembly (see picture, arrow) is opposite the control rod side.

Spacer plate KDEP 1057 for PE(S).. MW.. S1
KDEP 1591 for PE(S).. MW.. S1000. ..S1500
must be inserted between pump housing and barrel-and-valve assembly.

Fasten barrel-and-valve assembly with support plate, spring lock washer and hexagon nut.

D10

Assembling the injection pump

PE(S) .. MW .., 0 413 ..





13.2 Leak test on injection pump

Tilt pump (delivery-valve holders pointing downward).

Insert pump plunger into corresponding barrel-and-valve assembly.

Check for freedom of movement.

D11

Assembling the injection pump

PE(S) .. MW .., 0 413 ..



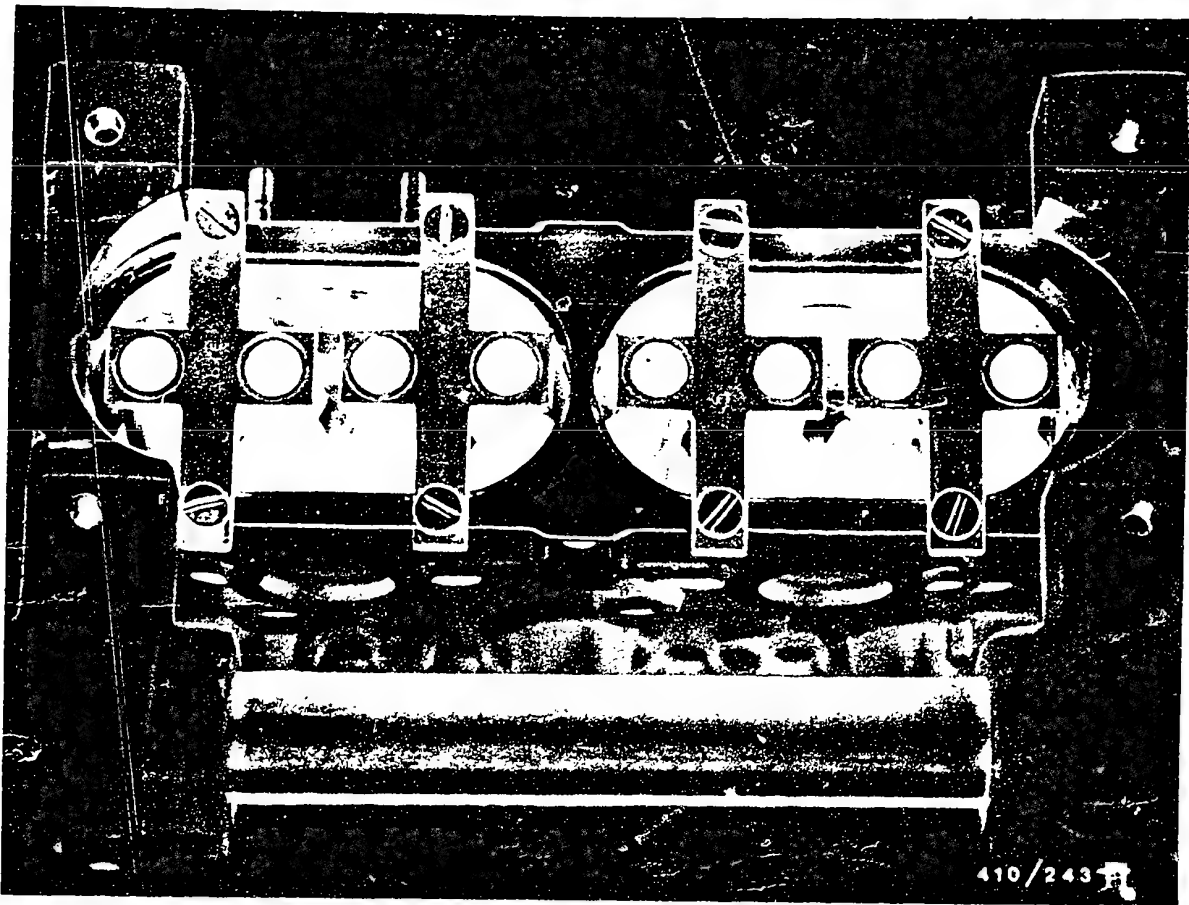

Fasten separation tubes KDEP 1052 or 1053 on pump housing with fillister-head screws (see picture).

D12

Assembling the injection pump

PE(S) .. MW .., 0 413 ..



Remove housing from clamping support.

Before immersing in calibrating oil, connect pump housing to compressed-air mains through pressure regulator with water trap.

To obtain the specified pressure reduction during the leak test, mount directional-control valve KDJE-P 100/1 of pressure tester KDJE-P 100 in the compressed-air inlet.

Seal unused fuel inlet connections.

Note:

To prevent possible skin rashes, grease hands beforehand with protective skin cream and wash with soap and water after testing.

D 13

Assembling the injection pump

PE(S) .. MW .., 0 413 ..



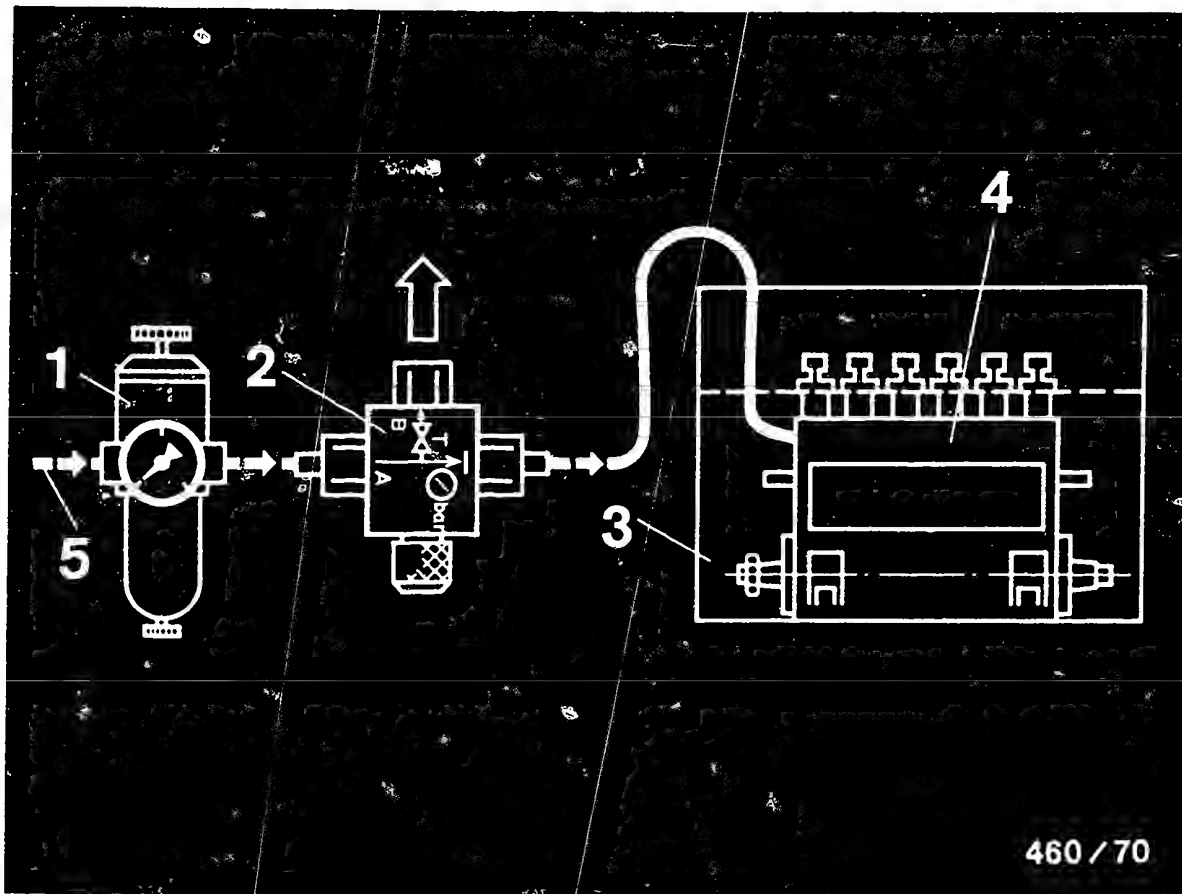

- 1 = Pressure regulator with pressure gauge 0...6 bar and water trap
- 2 = Directional-control valve KDJE-P 100/1
- 3 = Immersion tank with calibrating oil
- 4 = Injection pump
- 5 = Compressed air

With barrel-and-valve assemblies at the top, immerse pump in oil bath.

Test duration: 4 minutes at 5 bar, then
1 minute pulsating 0 to 5 bar

Leaks in the region of the suction gallery (suction-gallery end covers), delivery-valve holders, pump barrels (top and bottom) are not allowable.

D14

Assembling the injection pump

PE(S) .. MW .., 0 413 ..



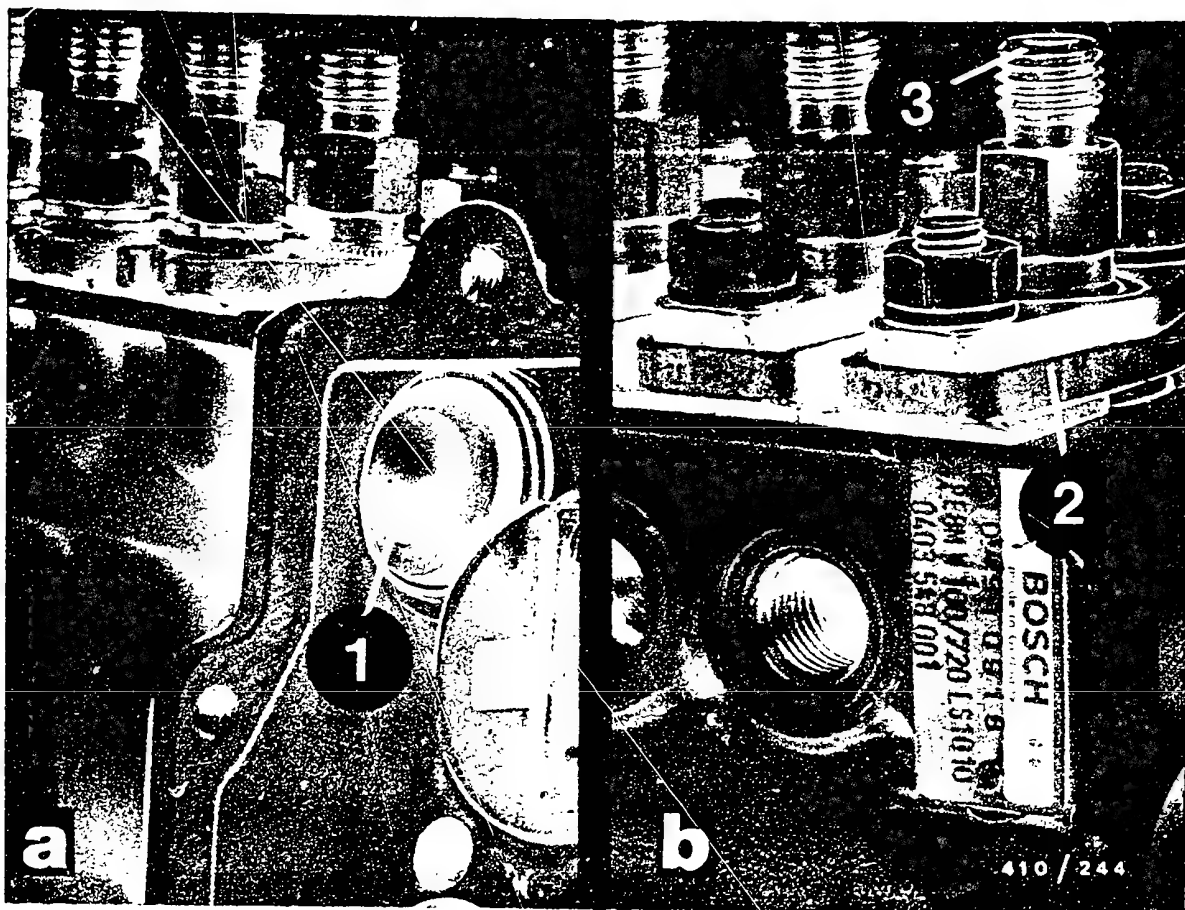

1 = Suction-gallery end cover
2 = Delivery-valve holder

3 = Delivery-valve holder taper

If there are leaks at the suction-gallery end cover, replace pump housing.

This does not apply to minor leaks between barrel and plunger as well as at the tapers (outlets) of the delivery-valve holders.

Pivot the pump in order to accurately locate leaks at the pump barrels. (Delivery-valve holders pointing downward.)

Take pump out of oil bath and mount on clamping support.

D 15

Assembling the injection pump

PE(S) .. MW .., 0 413 ..



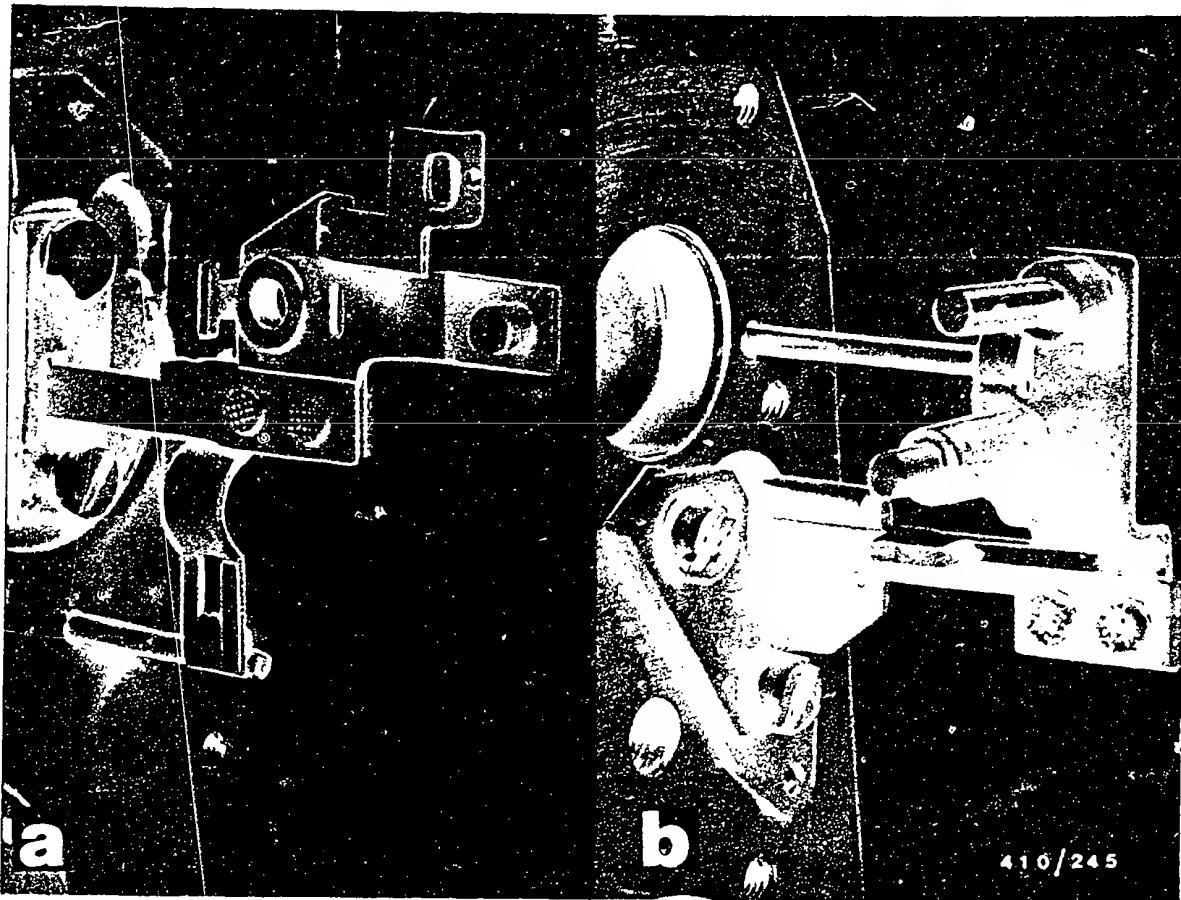

Remove separation tubes KDEP 1052 or 1053 and pump plungers.

Install control rod in pump housing.

Fasten with fastening screws and spring lock washers.

If applicable, mount short-circuit ring of control-rod travel sensor on control rod.

Picture a - PE(S).. MW.. S 1

Picture b - PE(S).. MW.. S 1000

.. S 1500

D 16

Assembling the injection pump

PE(S) .. MW .., 0 413 ..



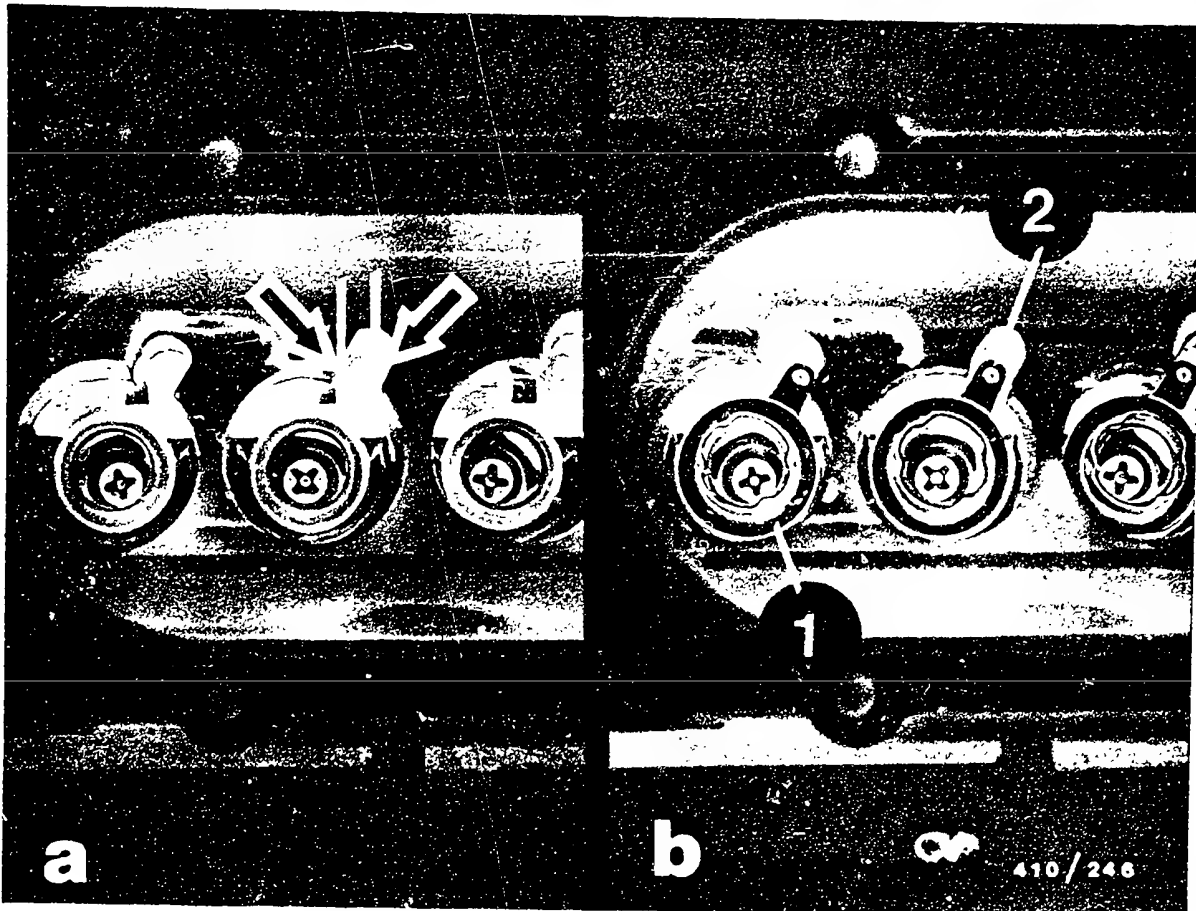

1 = Control sleeve

2 = Driving ball

13.3. Installing the components of the pump barrel

Fix the control rod so that the guide slits in the control rod align with the recesses in the housing (see picture a).

When the control sleeves are inserted, the driving balls must come into engagement with the guide slits.

Check the control rod for freedom of movement.

D17

Assembling the injection pump

PE(S) .. MW .., 0 413 ..



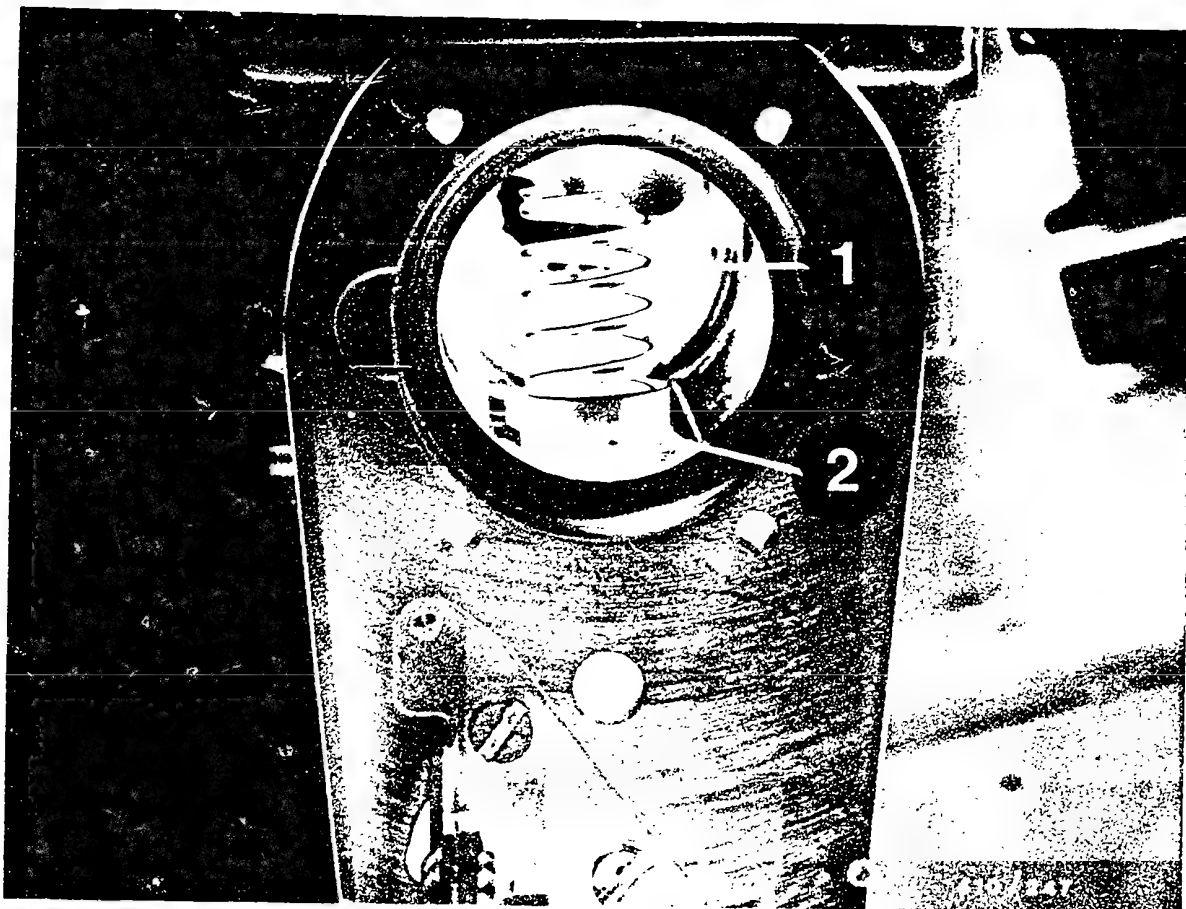

1 = Plunger spring

2 = Upper spring seat

Stick spring seat on plunger spring with grease.

Introduce spring seat and plunger spring together into pump housing (see picture).

D18

Assembling the injection pump

PE(S) .. MW .., 0 413 ..



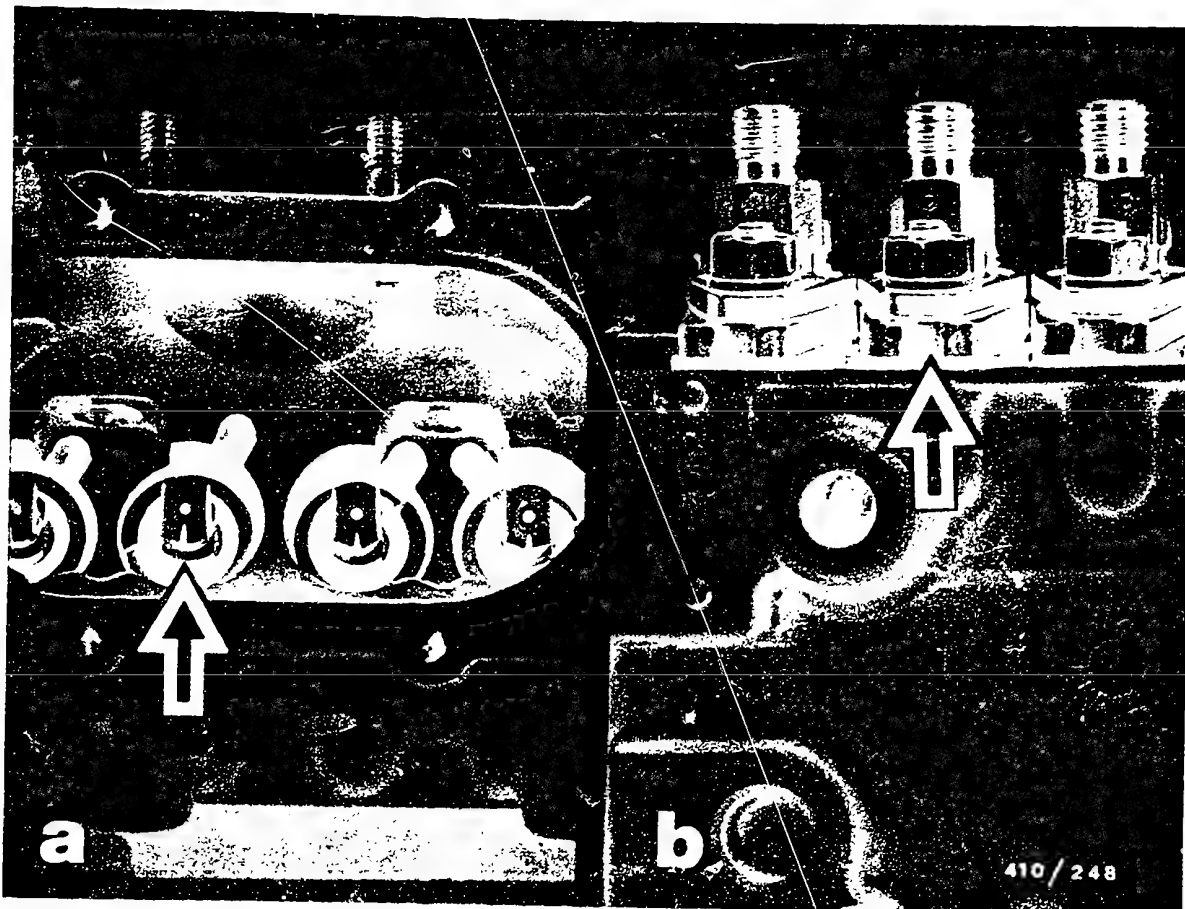

Wet pump plunger with calibrating oil and insert in pump barrel.

Check pump plunger for freedom of movement.

Note:

When inserting, the notched mark on the plunger base (see picture a, arrow) must point toward the adjusting groove (see picture b, arrow) in the barrel-and-valve assembly.

D19

Assembling the injection pump

PE(S) .. MW .., 0 413 ..



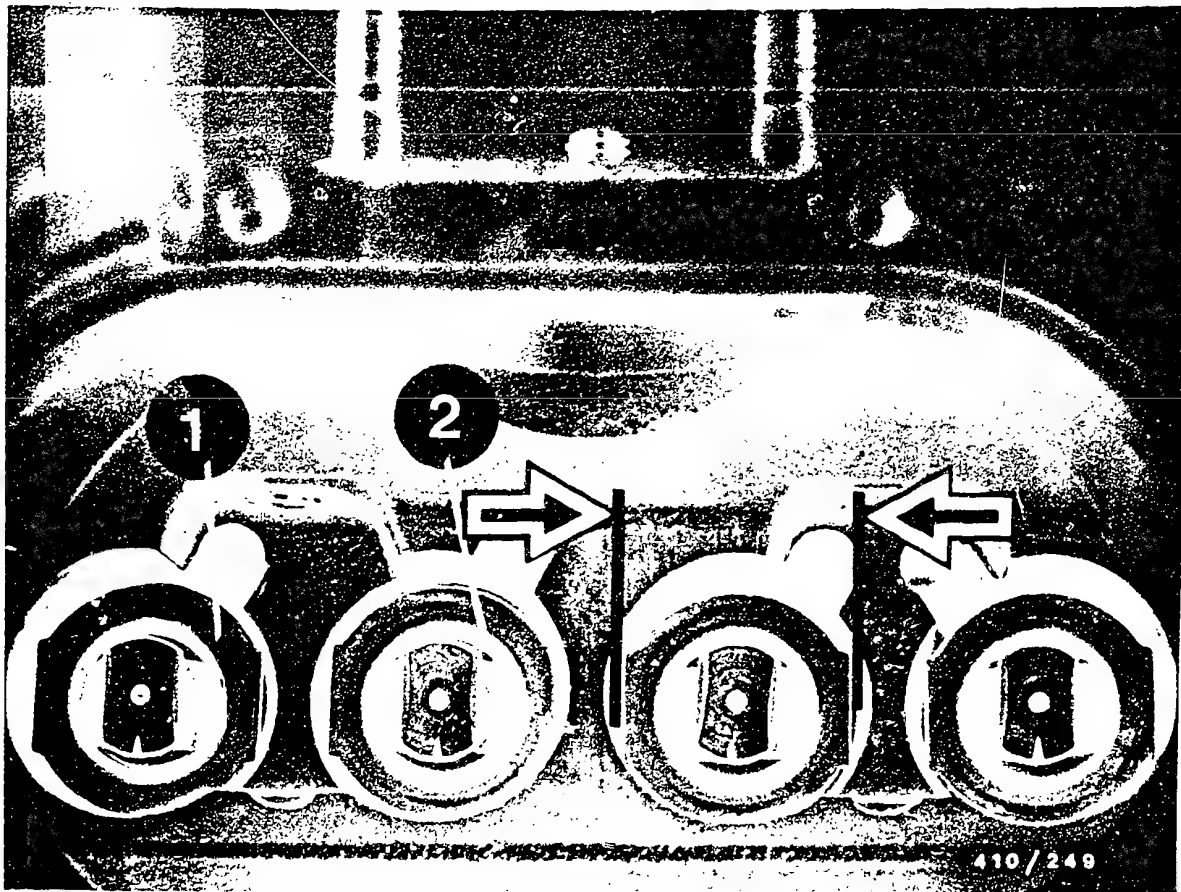

1 = Lower spring seat

2 = Curved side

Slide the lower spring seat, curved side first, over the plunger base.

Turn spring seat through 90° and align as in picture (do not turn pump plunger).

D20

Assembling the injection pump

PE(S) .. MW .., 0 413 ..



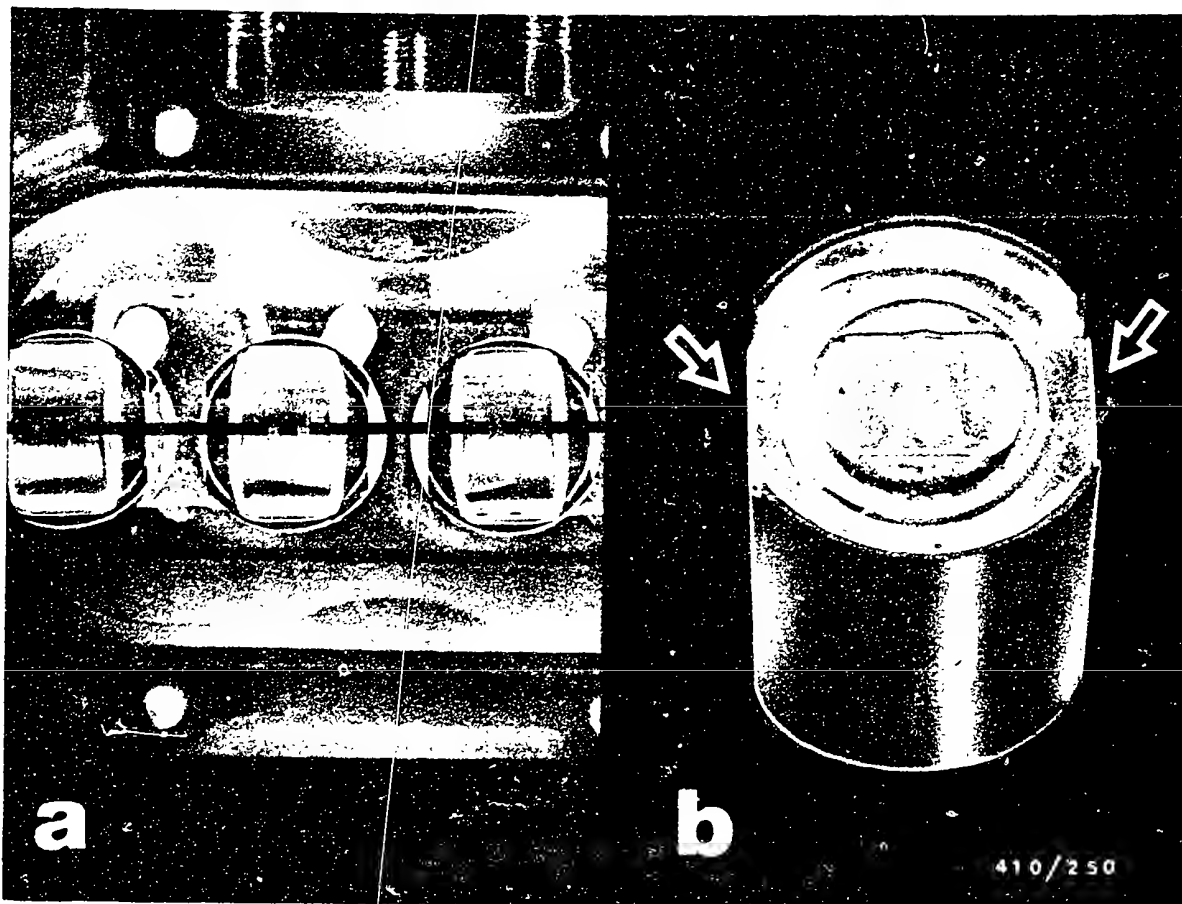

Introduce roller tappet into pump housing so that the roller axis is parallel to the pump axis (see picture a).

Note:

When inserting the roller tappets, make sure that the two flats on the spring seat (see picture b, arrows) align with the recess for accommodating the spring seat in the roller tappet.

D21

Assembling the injection pump

PE(S) .. MW .., 0 413 ..



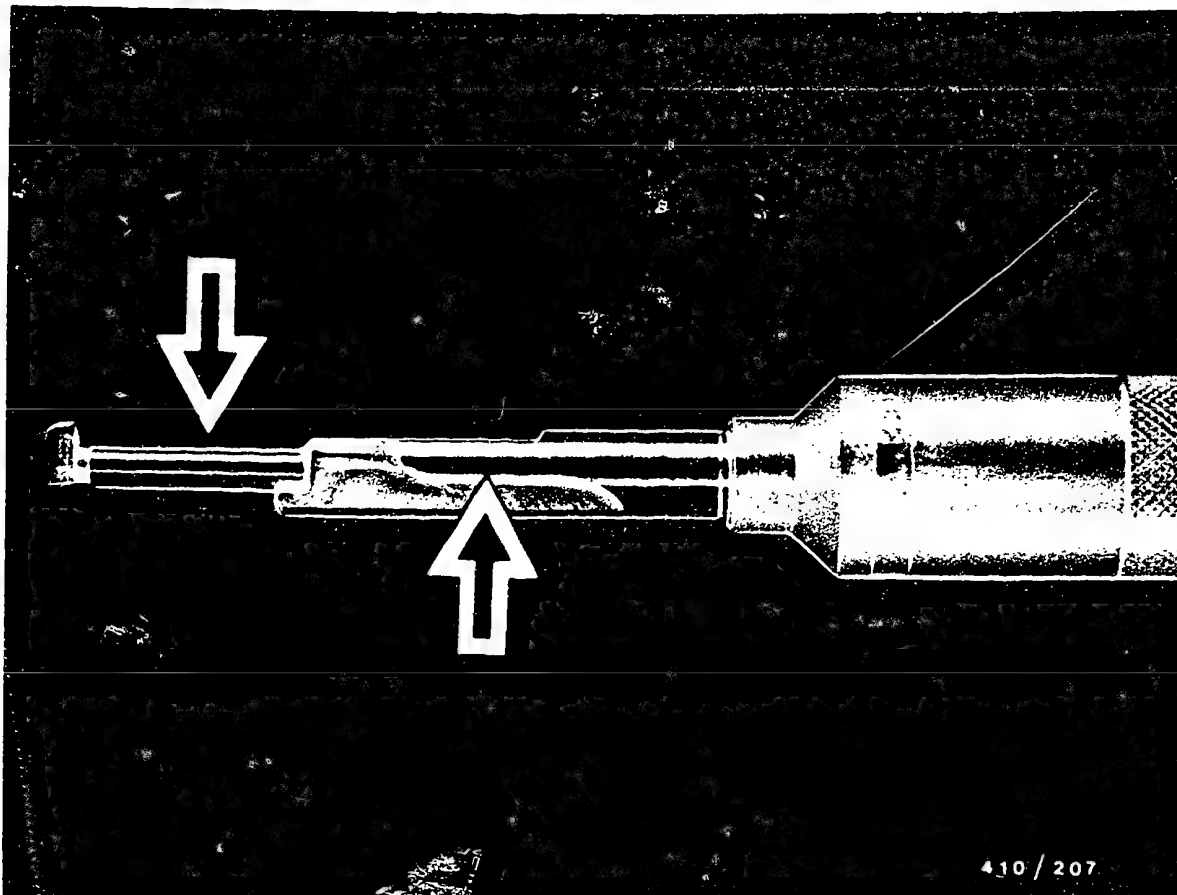

13.4 Installing the tappet holders

Mount assembly device KDEP 1505.

Turn rotatable handle of tappet holder

KDEP 1051 (PE(S).. MW.. S1) or
KDEP 1068 (PE(S).. MW.. S1000 and S1500)

as far as it will go in a counterclockwise direction.

Coat holding edges and guide piece (see picture, arrows)
of tappet holder with grease.



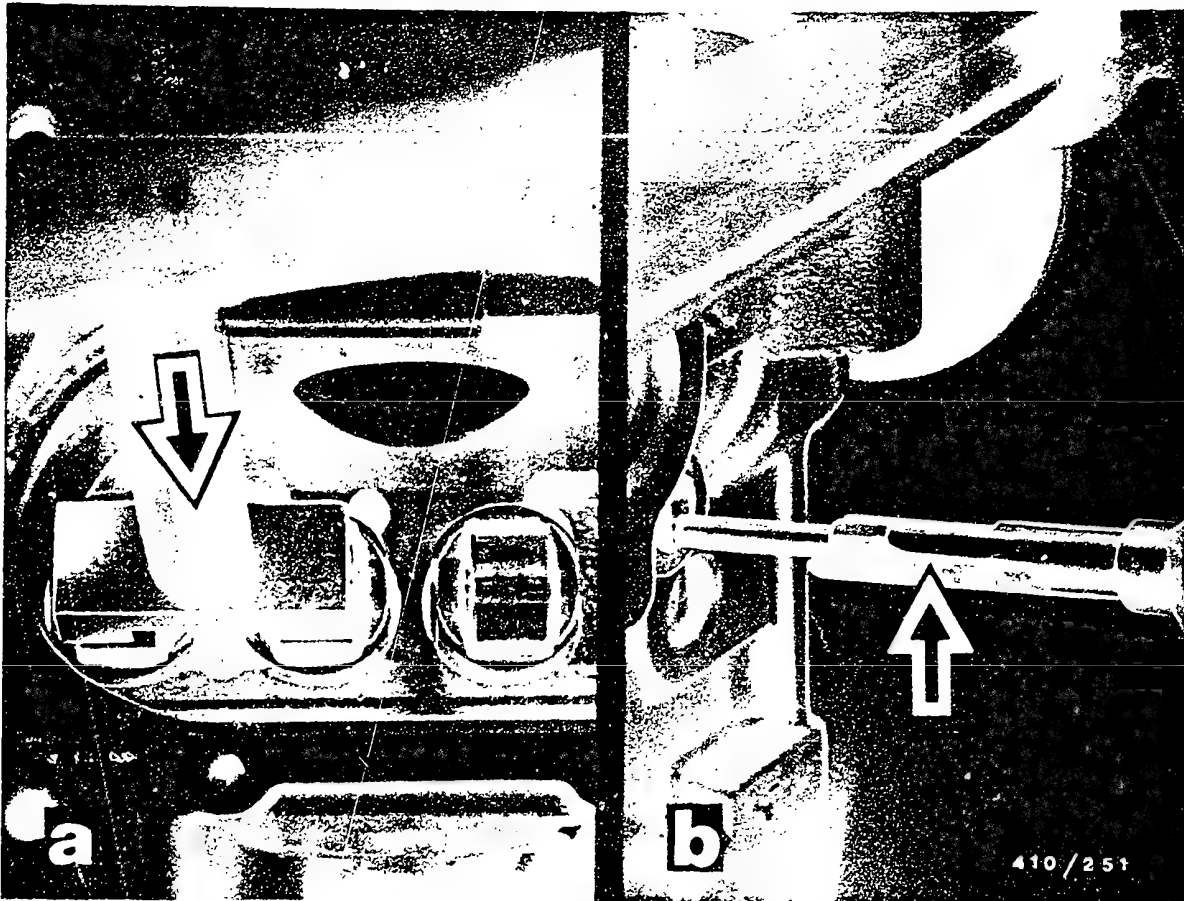

Using thrust piece, lightly press down roller tappets in pairs (see picture a - arrow).

While doing this, move control rod slightly backward and forward until plunger control arm engages control sleeve.

In this position, press roller tappet into TDC position.

Press (do not knock) tappet holder as far as it will go into lateral bore of spacer pin with holding edges facing upward (see picture b, arrow).

Relieve pressure on roller tappets.

The other tappet holders are installed in the same manner.

D23

Assembling the injection pump

PE(S) .. MW .., 0 413 ..



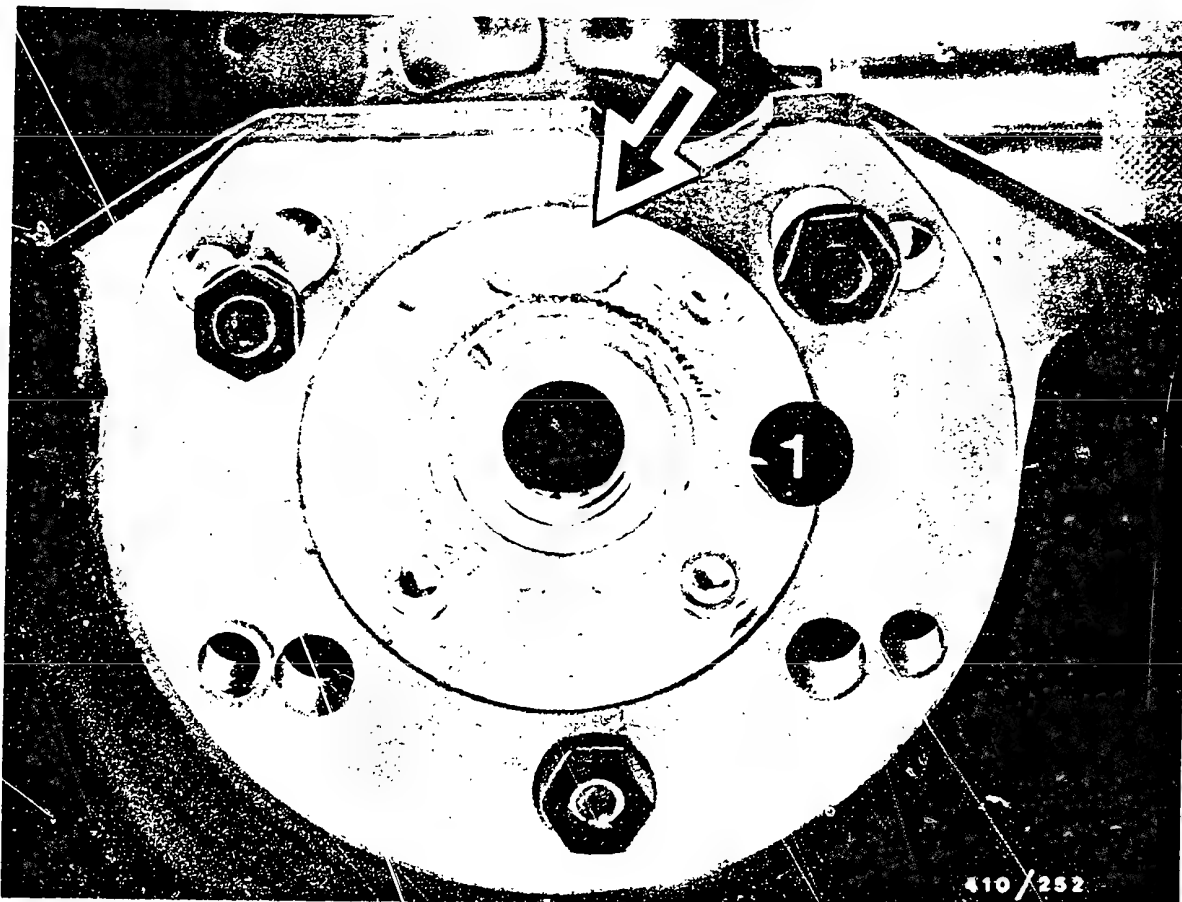

1 = Radial-lip-type oil seal

13.5 Mounting the bearing end plate

Mount bearing end plate with gasket on pump housing so that oil return bore (see picture, arrow) is at the top.

Do not yet mount radial-lip-type oil seal.

D24

Assembling the injection pump

PE(S) .. MW .., 0 413 ..



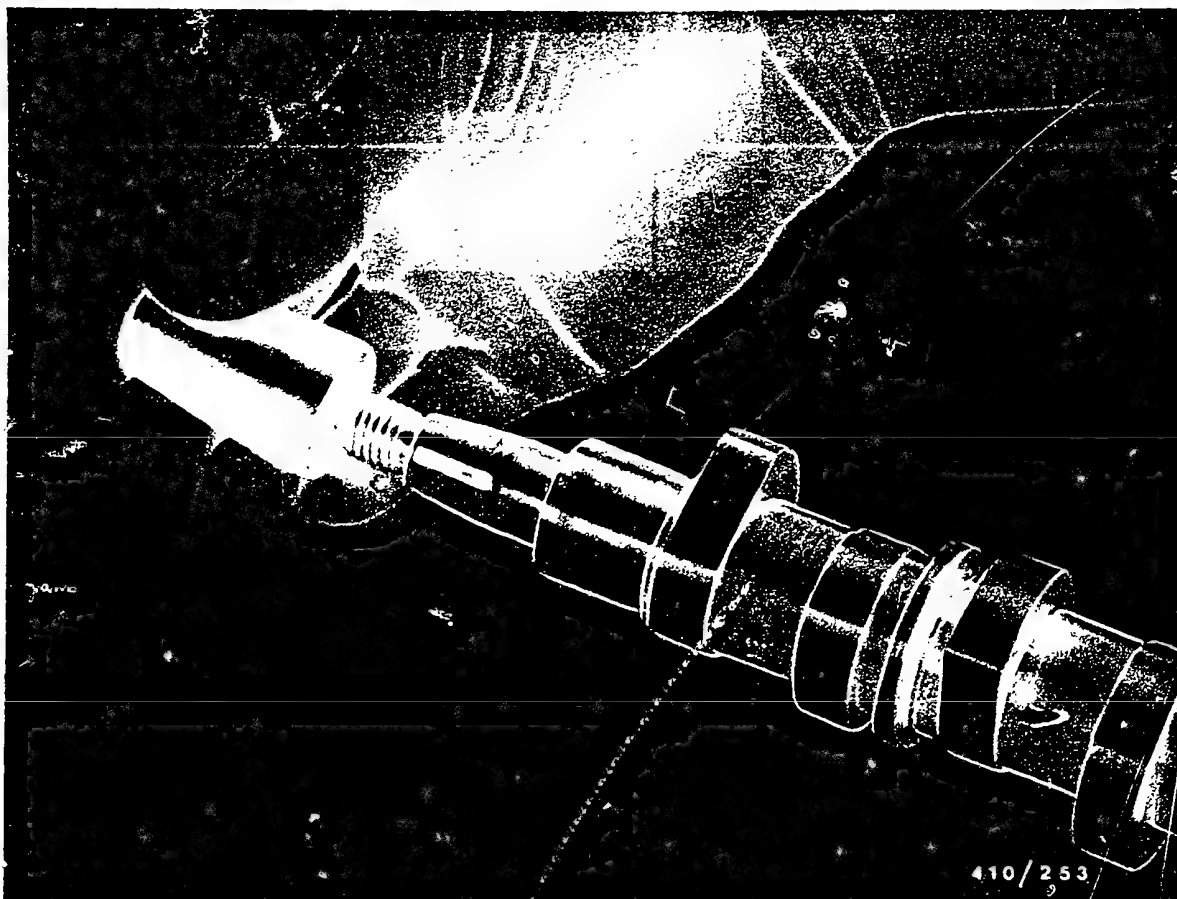

13.6 Installing the camshaft

Screw mounting sleeve KDEP 1054 (to protect the needle
rollers)

(for 17 mm cone)

or

KDEP 1055 (for 20 mm cone)

onto cone and threaded shaft end.

Note:

No mounting sleeve is required for injection pumps with
25 mm cone.

Stick intermediate bearing (if applicable) on camshaft
bearing point with grease.

E1

Assembling the injection pump

PE(S) .. MW .., 0 413 ..



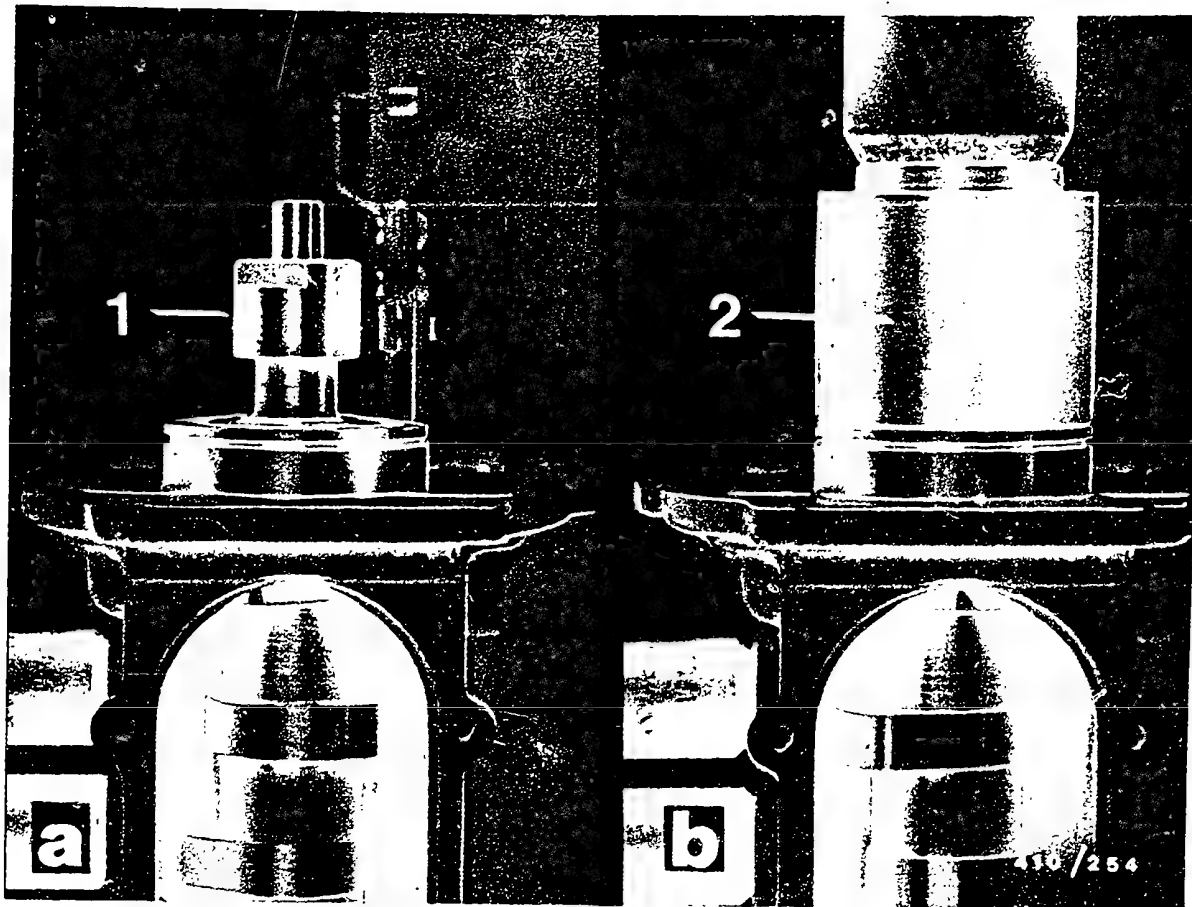

1 = Guide sleeve

2 = Press-in sleeve

- PE(S).. MW..S1 with 8 mm stroke

Remove injection pump from clamping support.

Introduce camshaft with intermediate bearing (if applicable) into pump housing.

Screw guide sleeve (contained in parts set of press-in tool KDEP 1060) onto camshaft.

Slide press-in sleeve over guide sleeve and, under an arbor press, press deep-groove ball bearing as far as it will go into pump housing.

Note:

Press only on the outer race of the deep-groove ball bearing.

E2

Assembling the injection pump

PE(S) .. MW .., 0 413 ..



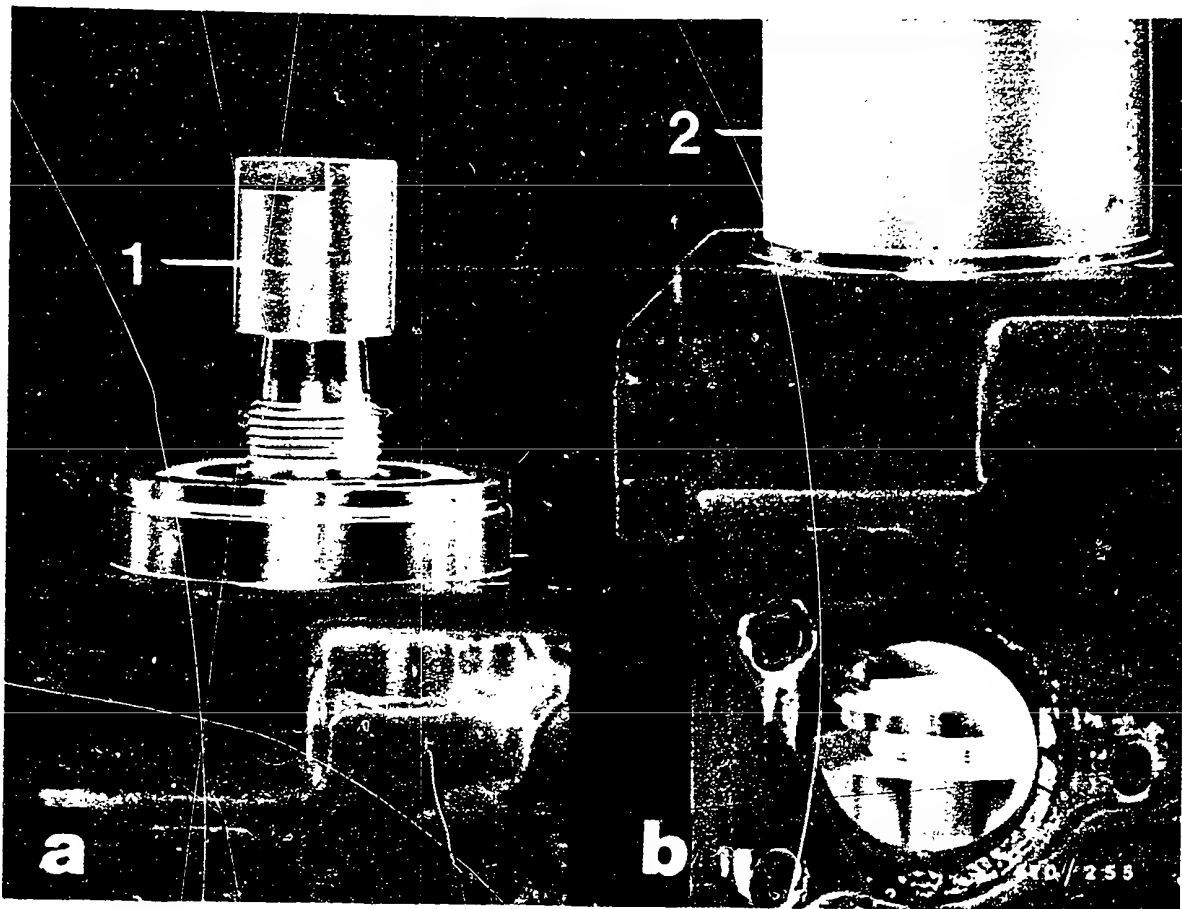

1 = Guide sleeve

2 = Press-in sleeve

- PE(S).. MW..S1000 and ..S1500 with 10 mm stroke

Remove injection pump from clamping support.

Introduce camshaft with intermediate bearing (if applicable) into pump housing.

Screw guide sleeve (contained in parts set of press-in tool KDEP 1069) onto camshaft.

Slide press-in sleeve over guide sleeve and, under an arbor press, press in deep-groove bearing as far as it will go.

Note:

Press only on the outer race of the deep-groove ball bearing.

E3

Assembling the injection pump

PE(S) .. MW .., 0 413 ..



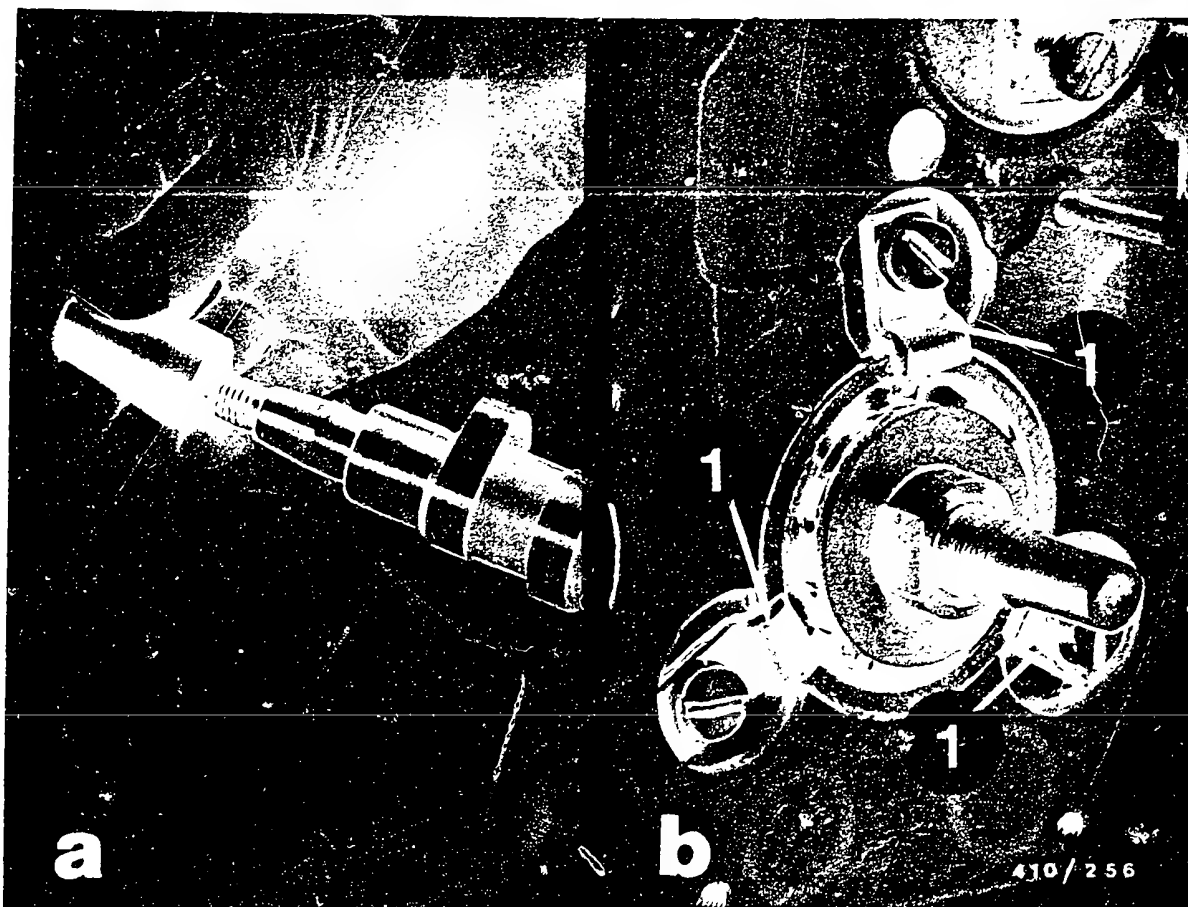

1 = Holding plates

Remove mounting sleeve KDEP 1054 or 1055 (to protect the needle-roller bearings).

Unscrew guide bushing from camshaft.

Fasten holding plates with fillister-head screw and spring washer.

Tighten fillister-head screws to a torque of 4 ... 7 Nm (see picture b).

E4

Assembling the injection pump

PE(S) .. MW .., 0 413 ..



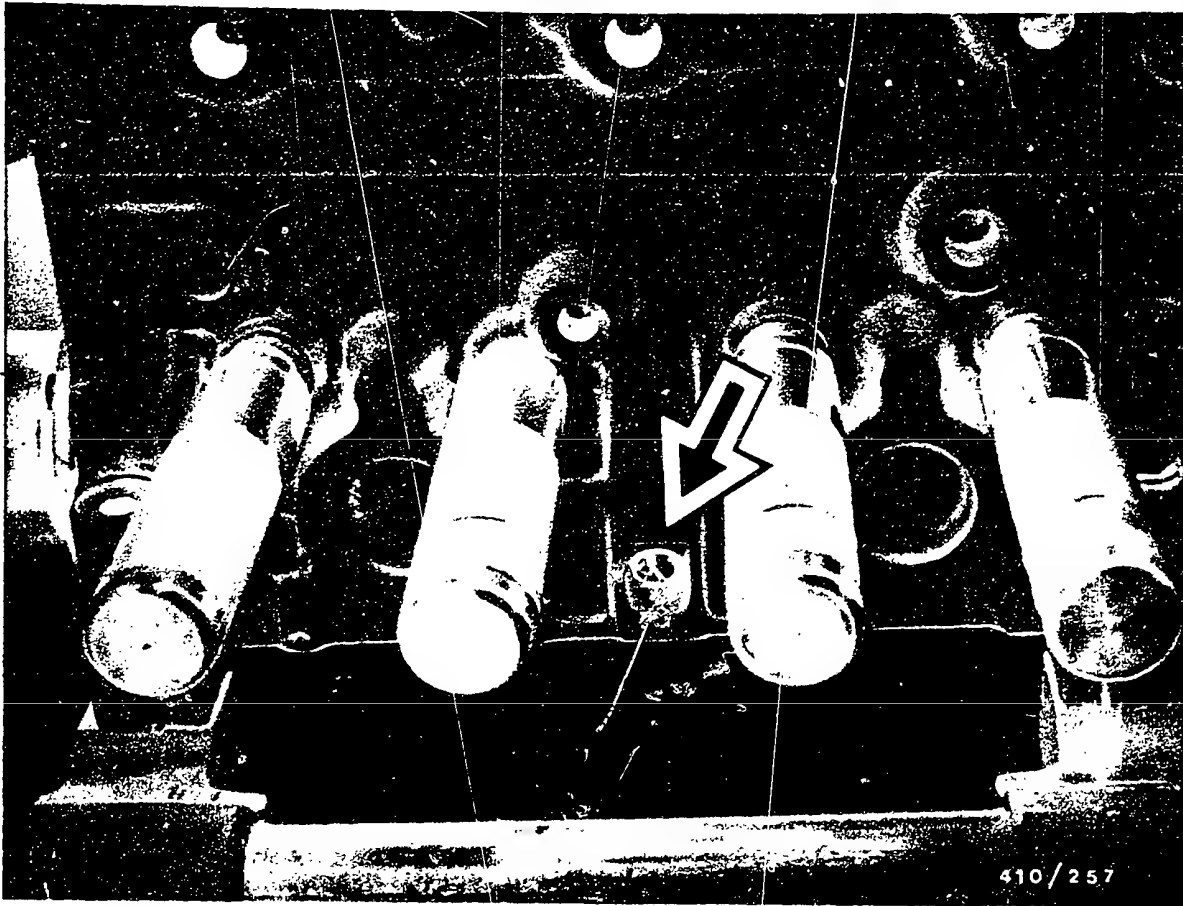

Fasten intermediate bearing (if applicable - see picture, arrow) with fastening screws.

Note:

Use only new screws as per service-parts list.

Coat thread of screw with Loctite 638.

Install USIT seal ring as per service-parts list (do not use a copper seal ring).

Pretighten fastening screws on both sides uniformly to 5 Nm and tighten to a final tightening torque of 8 ... 10 Nm.

E5

Assembling the injection pump

PE(S) ... MW ... 0 413 ...





13.7 Installing the radial-lip-type oil seal at the drive end

Note:

If the pump has an alternating-spiral seal ring (see picture) the once and the sealing surface must be grease-free when inserting the camshaft.

Pack double-lip seal ring between the sealing lips with high-temperature bearing grease 5 700 002 025.

E6

Assembling the injection pump

PE(S) .. MW .., 0 413 ..



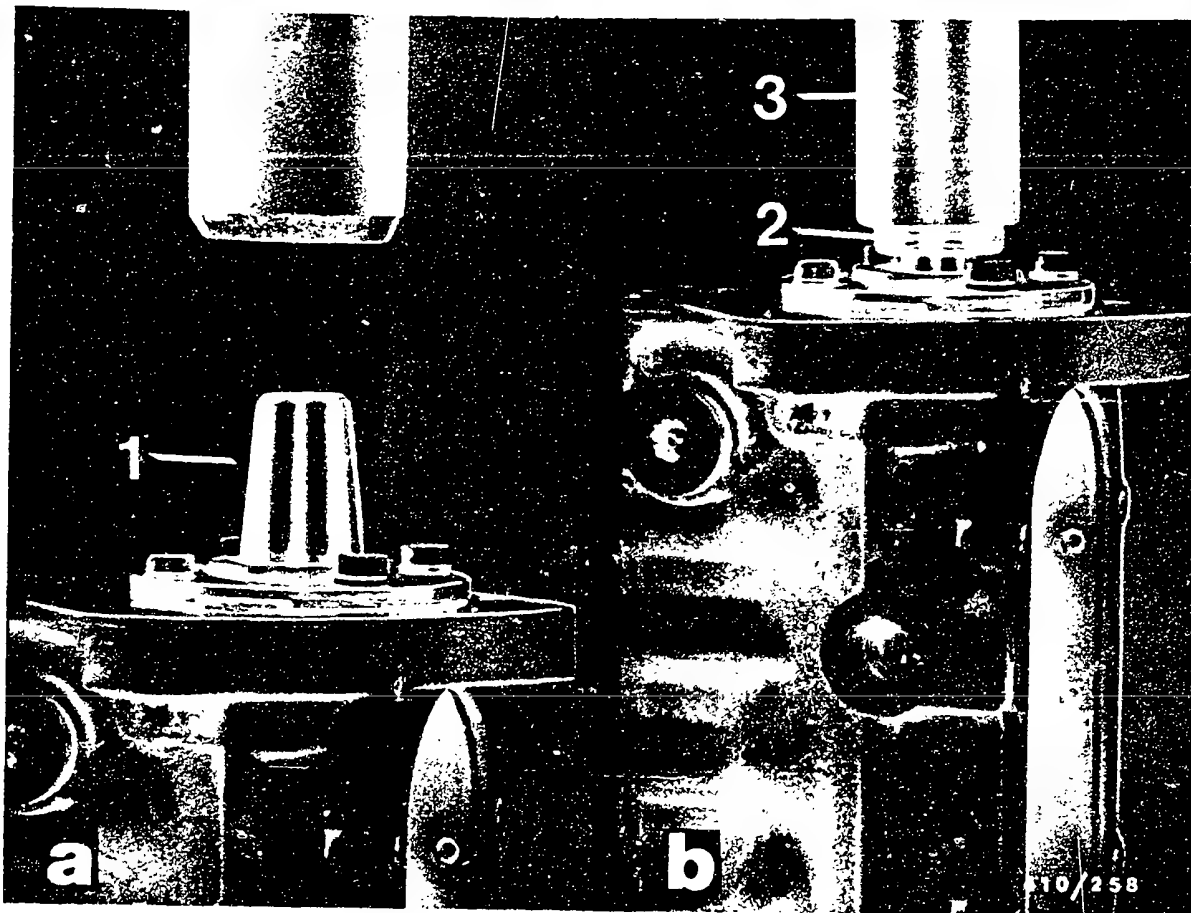

1 = Mounting sleeve

2 = Radial-lip-type oil seal

3 = Press-in sleeve

To protect the radial-lip type oil seal, screw appropriate mounting sleeve (KDEP 1874, ... 1876, ... 2925) onto cone of camshaft.

Grease outer circumference of radial-lip-type oil seal with grease 5 700 002 .. (Ft 1v4) and press in flush with press-in sleeve KDEP 1594.

Remove mounting sleeve.

E7

Assembling the injection pump

PE(S) .. MW .., 0 413 ..



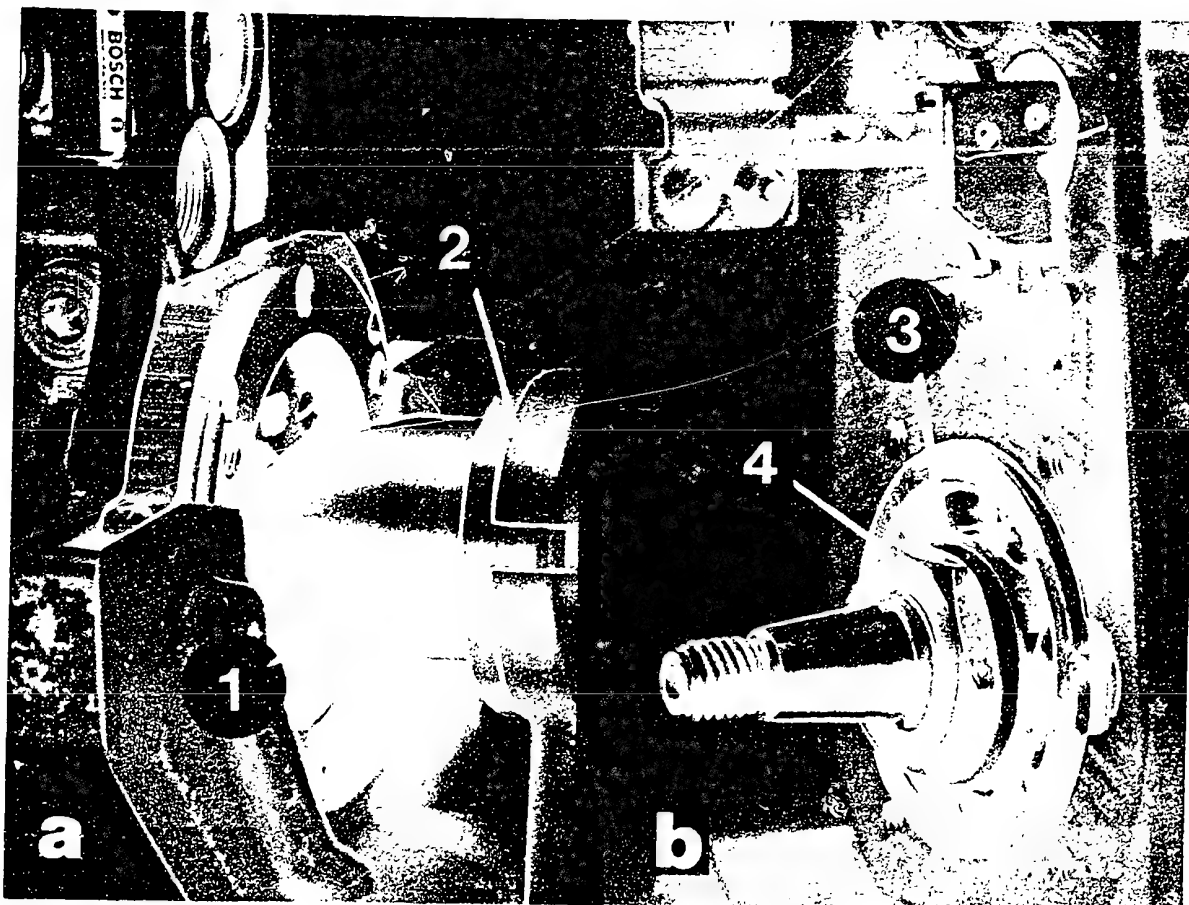

1 = Drive coupling
2 = Holding wrench

3 = Washer
4 = Hexagon nut

13.8 Mounting the drive coupling

Mount injection pump on clamping support.

Mount drive coupling with Woodruff key on camshaft.

-PE(S).. MW.. S1000, ..S1500

Screw hexagon nut with washer onto camshaft and tighten to 100 ... 120 Nm.

Hold drive coupling with holding wrench KDEP 2906 or KDEP 2885.

E8

Assembling the injection pump

PE(S) .. MW ... 0 413 ..



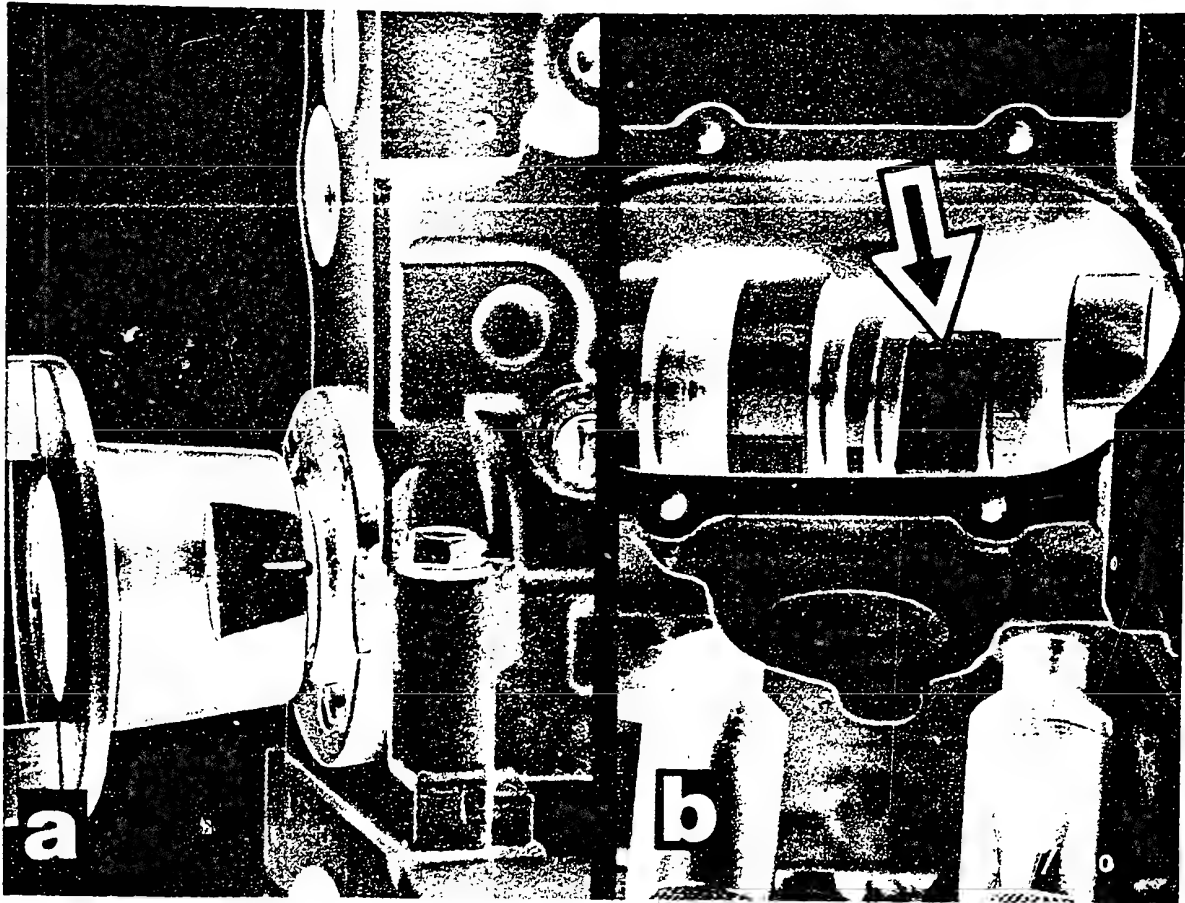

13.9 Removing the tappet holders

Turn camshaft until the cam to the left of the tappet holder (see picture b, arrow) is at TDC.

E9

Assembling the injection pump

PE(S) .. MW .., 0 413 ..



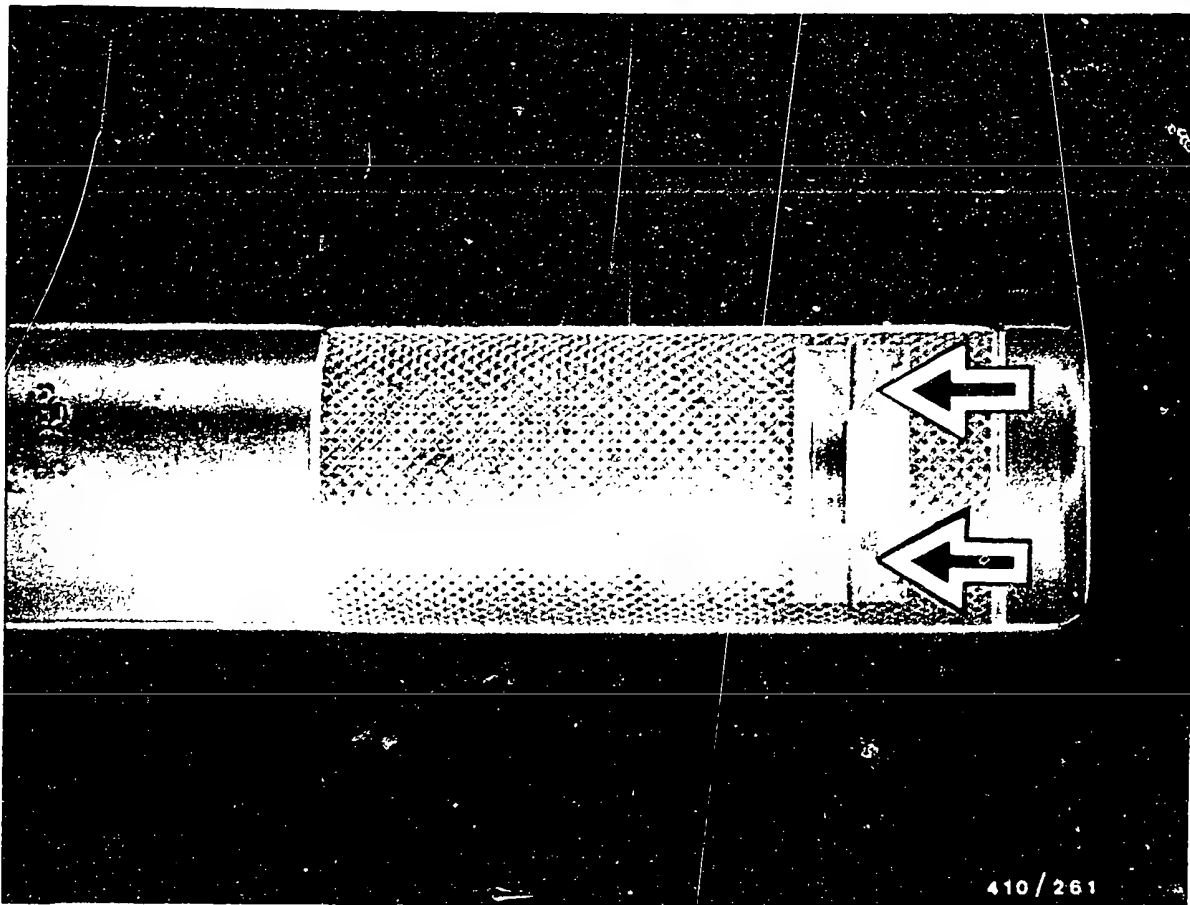

By turning the handle in a clockwise direction, withdraw the tappet holder until the end face of the stop nut aligns with the mark in the sight window of the tappet holder (see picture, arrow).

In this position, the left-hand roller tappet is resting on the camshaft.

E10

Assembling the injection pump

PE(S) .. MW .., 0 413 ..



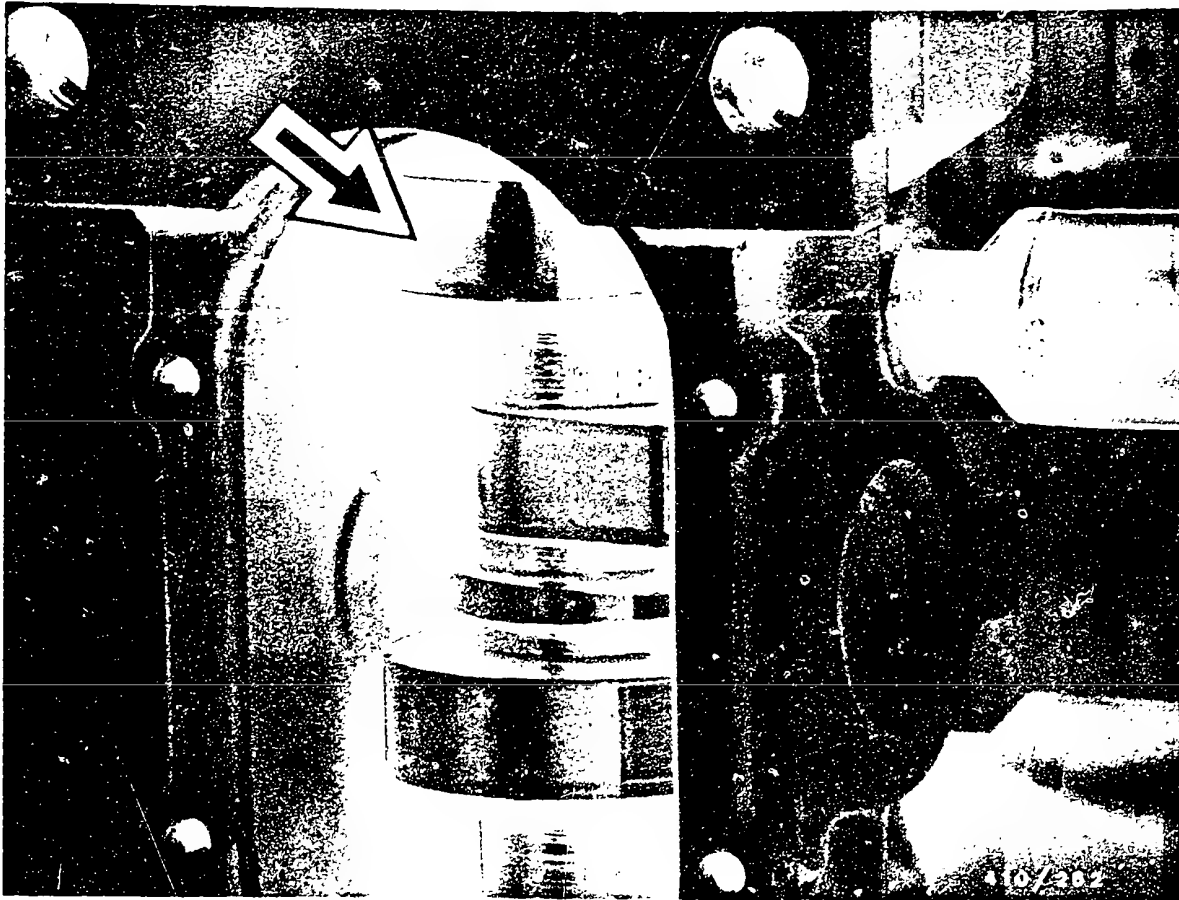

Hold the tappet holder with your hand.

Turn camshaft until cam to the right of the tappet holder (see picture, arrow) is at TDC.

Withdraw tappet holder entirely.

The remaining tappet holders are removed in the same manner.

E11

Assembling the injection pump

PE(S) .. MW .., 0 413 ..



Note:

In 5-cylinder injection pumps, roller tappet 3 holds only the roller tappet of barrel 5.

If the tappet holders are removed in the wrong order, there is the danger that the roller tappets will impact suddenly on the camshaft.

This may lead to hairline cracks in the roller of the roller tappet.

In such a case, the rollers must be checked once again for damage.

E12

Assembling the injection pump

PE(S) .. MW .., 0 413 ..



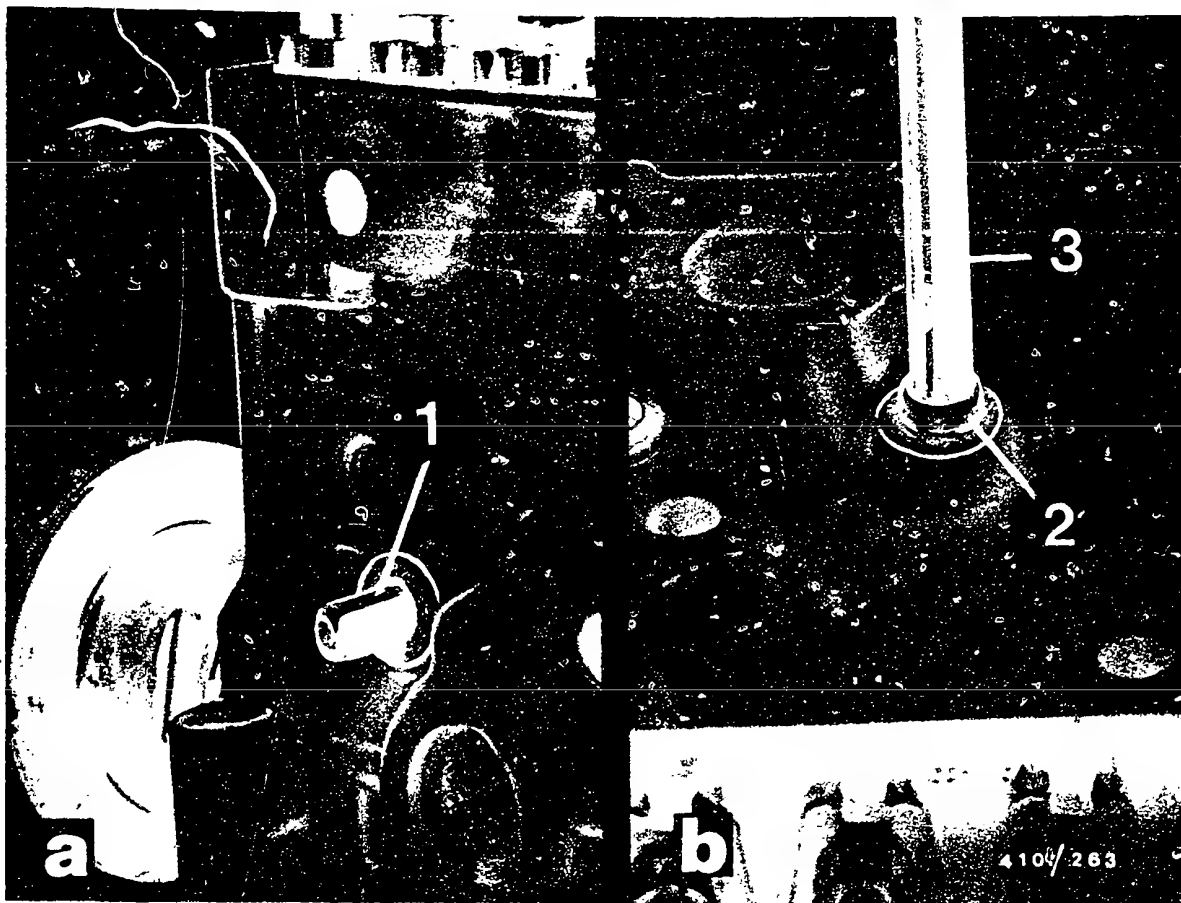

1 = Spacer pin
3 = Press-in mandrel

2 = Capsule

13.10 Final assembly

Degrease spacer pin housing bores.

Introduce spacer pin into pump housing.

Coat new capsules with Loctite 601 and, using press-in mandrel KDEP 1058, press into pump housing as far as they will go.

Note:

Loctite 601 takes approx 3 hours to set at 20°C.

E13

Assembling the injection pump

PE(S) .. MW .., 0 413 ..



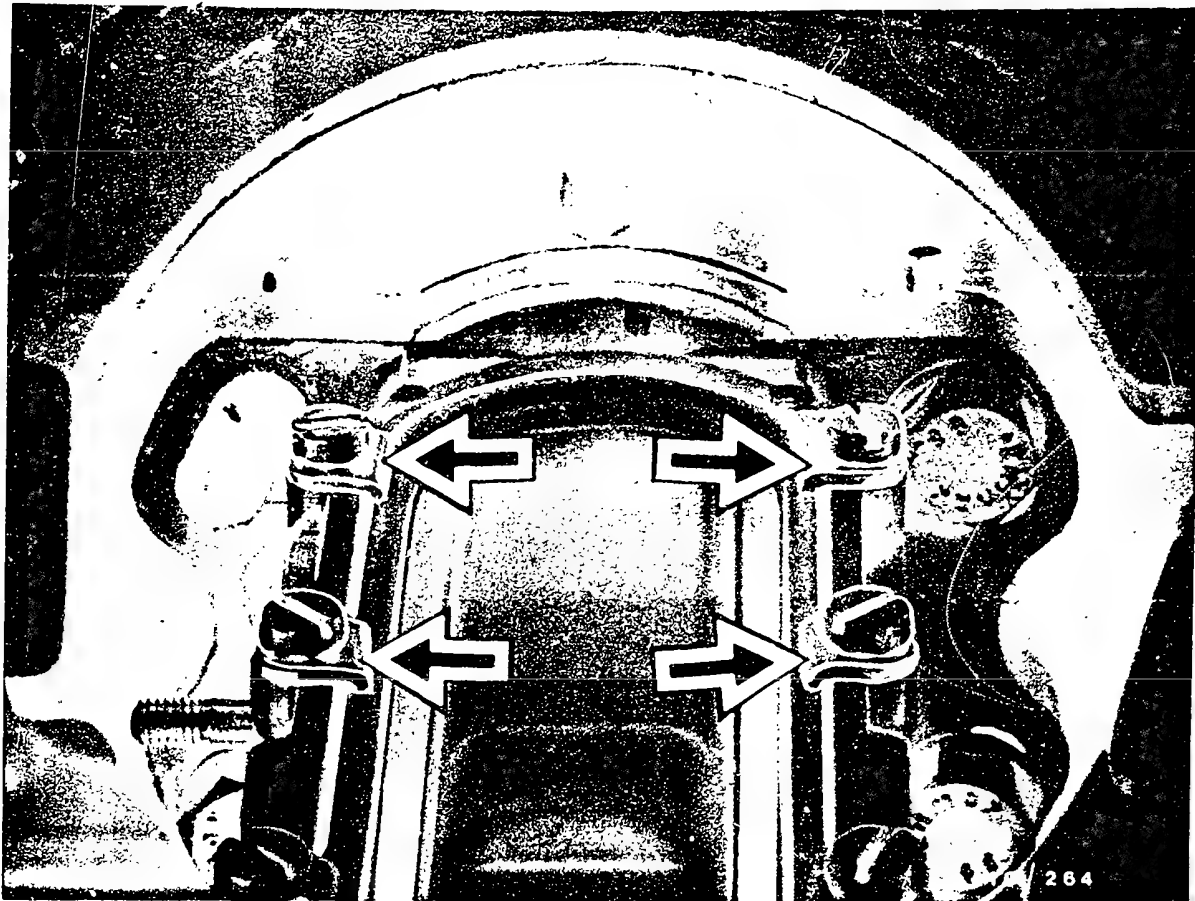

Place seal ring on closing cover.

Mount closing cover with lock washers (see picture, arrows) and fillister-head screws.

Tighten fillister-head screws to 4 ... 7 Nm.

E14

Assembling the injection pump

PE(S) .. MW .., 0 413 ..



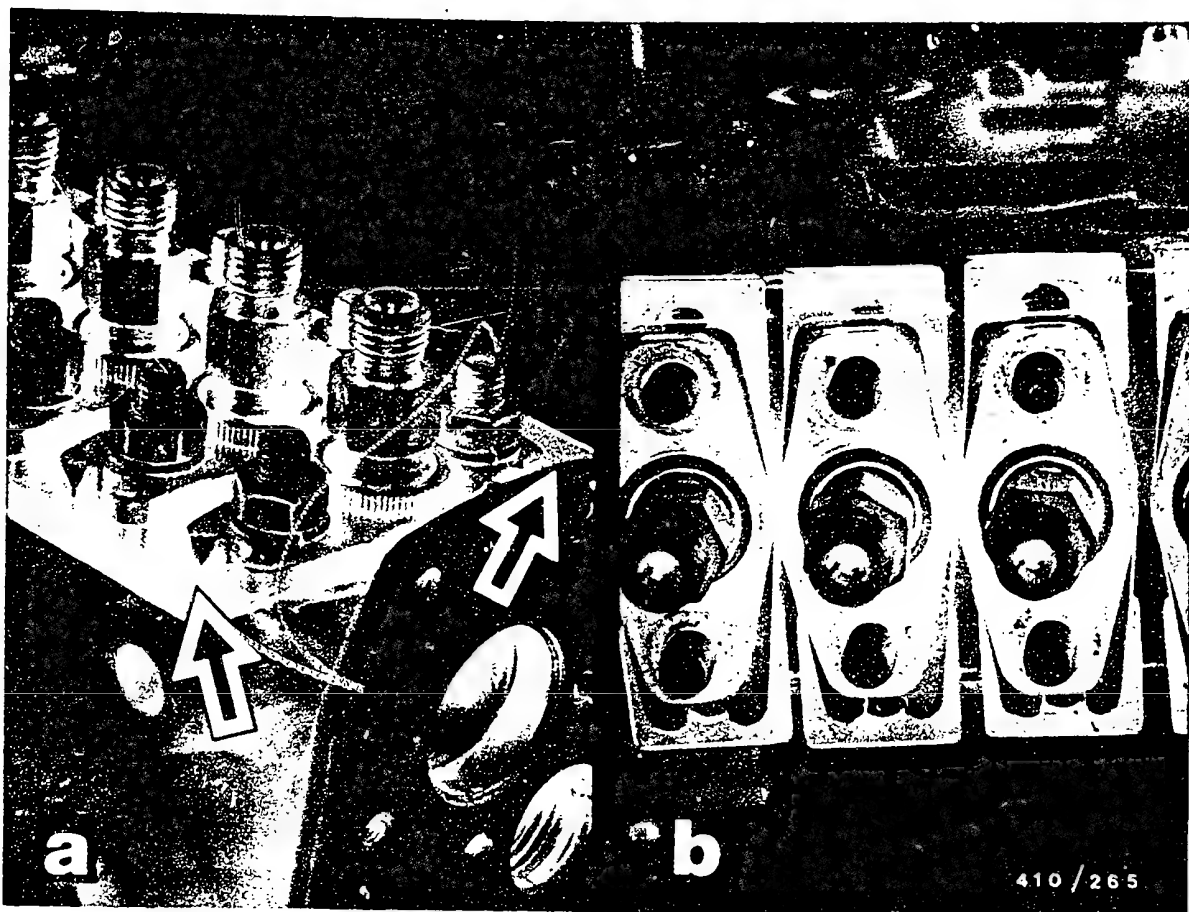

Loosen hexagon nuts and remove both spacer plates KDEP 1057 or KDEP 1591 (see picture a, arrow).

Insert prestroke adjusting shims approx 2 mm thick between barrel-and-valve assembly and pump housing (see picture b).

Tighten hexagon nuts to 20 ... 25 Nm.

E15

Assembling the injection pump

PE(S) .. MW .., 0 413 ..



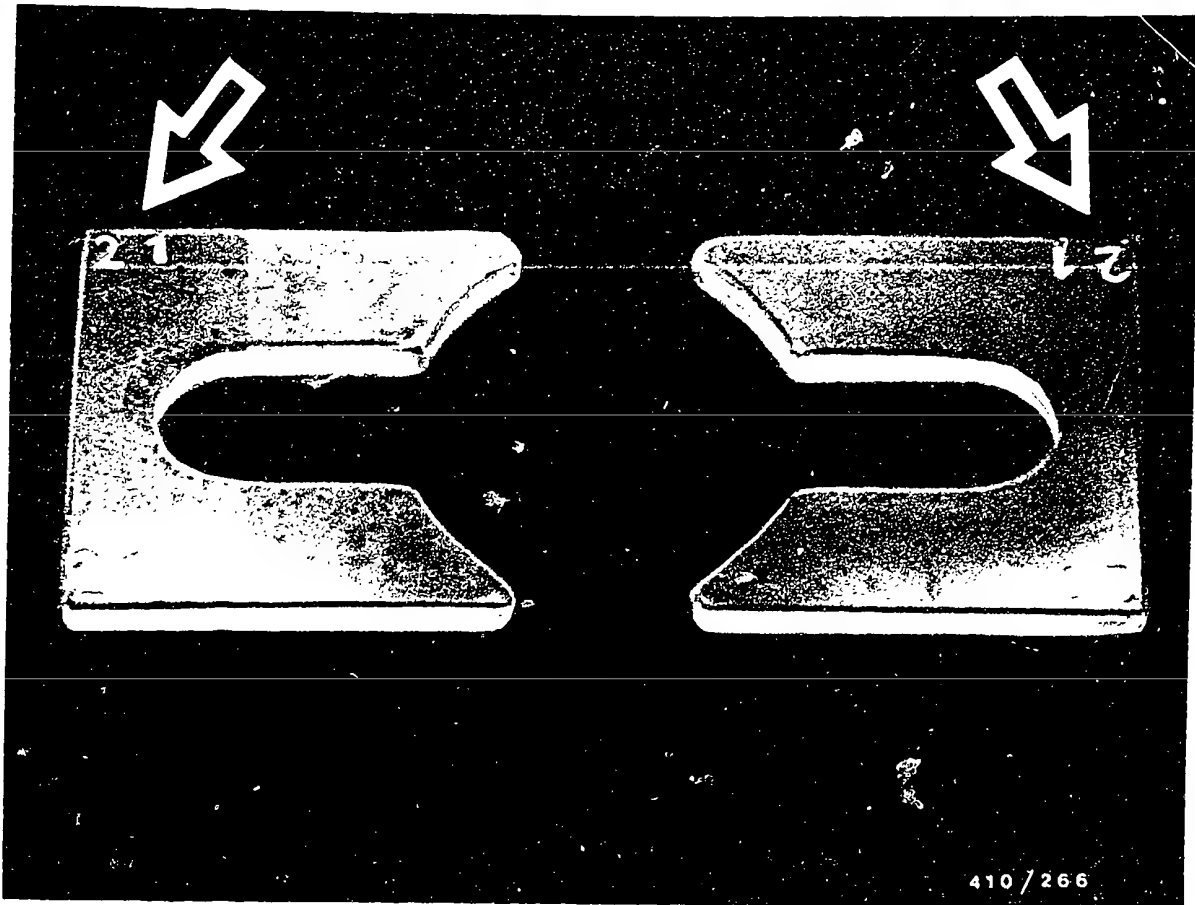

Note:

Prestroke adjusting shims must be of identical thickness and must be identically marked (see picture, arrows) for each barrel-and-valve assembly.

E16

Assembling the injection pump

PE(S) .. MW .., 0 413 ..



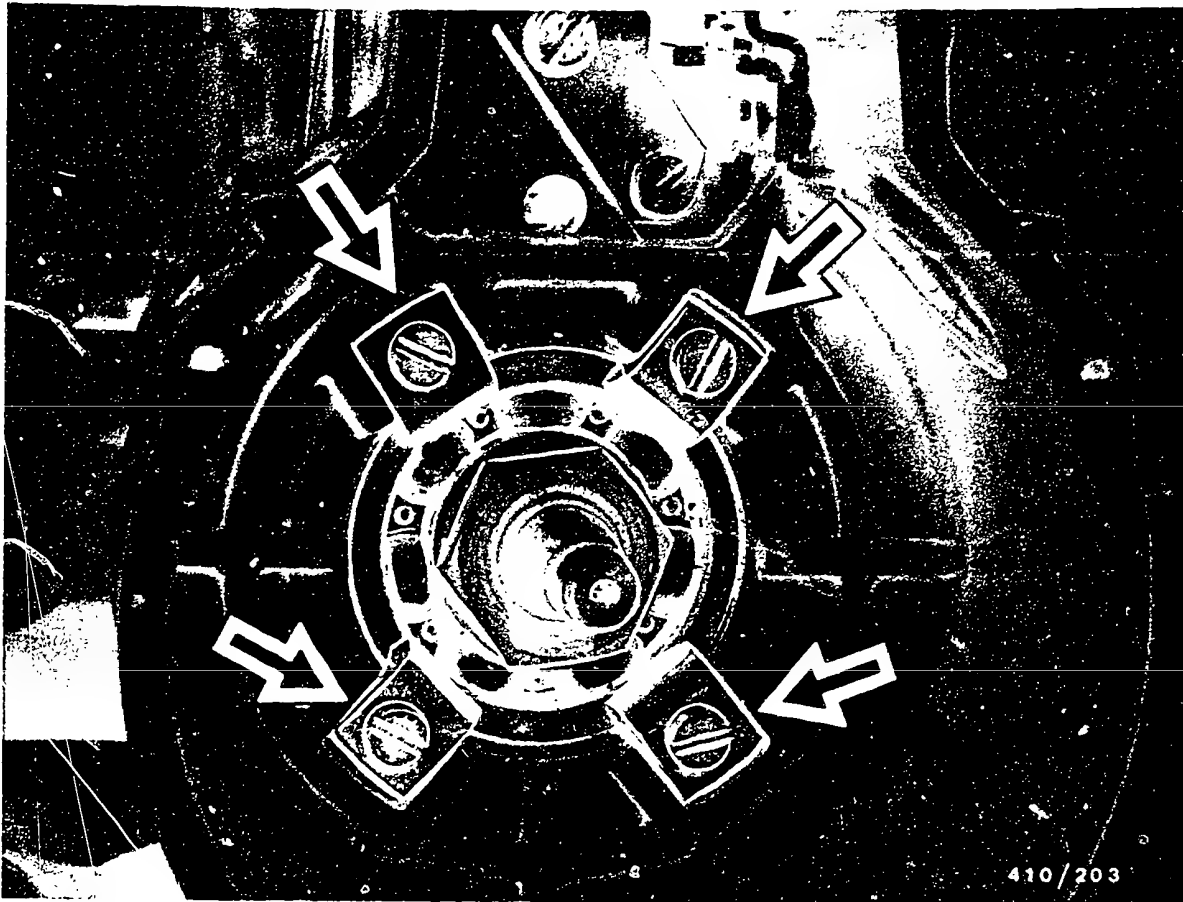

Mount governor housing with seal and holding plates (according to version) (see picture, arrows) on pump housing.

If applicable, mount control-rod-travel sensor and tighten to specified torque.

Assemble governor according to respective repair instructions.

Do not mount supply pump, timing device (if applicable), screw plug with flat seal ring or other connecting parts until after testing (setting) on the injection-pump test bench.

Remove injection pump from clamping support.

Note: If the injection pump is not to be set immediately, then mount the above-mentioned components.

E17

Assembling the injection pump

PE(S) .. MW .., 0 413 ..



Leak test on camshaft chamber

Finish off assembly of injection pump.

Compressed air is required for the leak test. Apply to the pump camshaft chamber at a suitable point (e.g. oil inspection bore).

Immerse injection pump vertically in oil bath.

Test duration and test pressure:

3 minutes	at	1.5 bar, then
1 minute	at	0.5 bar

Visually examine whether there are any leaks at joints, screw connections, seal rings and end covers on housing and cover.

No air bubbles must be visible.

To prevent possible skin rashes, grease hands beforehand with protective skin cream and wash with soap and water after testing is completed.



After-sales Service

Technical Bulletin

Only for use within the Bosch organization. Not to be communicated to any third party.

FASTENING THE CAMSHAFT INTERMEDIATE BEARING

VDT-I-413/105 En

2.1983

on PE(S)...MW...S1000 and
S1100 fuel-injection pumps

(Supersedes 12.1981 edition)

In present series production and in the after-sales service use is made of hexagon-socket-head cap screws 2 914 552 121 with micro-encapsulation.

However, after a life of approx. 2 years micro-encapsulated screws do not offer sufficient safety against coming loose and must, therefore, not be re-used when repairs are carried out.

Proceed as follows in the case of fuel-injection pumps which must be repaired:

1. Use new screw 2 910 141 199 (hexagon-socket-head, property class 8.8)
2. Coat screw thread with Loctite (No. 638)
3. Use USIT seal ring 2 410 113 004 (not a copper seal ring)
4. Tightening torque
 - o Tighten the screws on both sides equally with 5 Nm
 - o Maintain a final tightening torque of 8...10 Nm.

Please purchase the new screws 2 910 141 199 in good time.

The screws 2 914 552 121 which you have in stock should be sent with warranty voucher G 20 for crediting to K5/QSG with reference to this Technical Bulletin.

Please state 0 400 999 999 as the defective product.

BOSCH

Geschäftsbereich IKH, Kundendienst, Kitz-AuerGating.
© by Robert Bosch GmbH, D-7 Stuttgart 1, Postfach 80. Printed in the Federal Republic of Germany.
Imprimé en République Fédérale d'Allemagne par Robert Bosch GmbH.

N1

Technical Bulletin

PE(S) .. MW .., 0 413 ..



After-sales Service

Technical Bulletin

Only for use within the Bosch organization. Not to be communicated to any third party.

Modification to tappet holder KDEP 1051

for PE(S) .. MW .. Fuel-injection pumps

41

VDT-I-413/1000 B

12. 1976

Modification to tappet holder KDEP 1051

The fuel-injection pumps of type PE(S) .. MW .. installed in Mercedes-Benz passenger cars have their connection orifice for pump plunger lubrication situated higher than other pumps of this type. Because of this, at least one tappet holder per tool kit must be adapted to meet this variation (see drawing).

The front part of the holder, diameter 14 mm, must be lengthened by 3 mm.

Note

This is a heat-treated steel part, and a carbide-tipped turning tool must be used. New tappet holder KDEP 1051 incorporating this modification will be supplied in future.

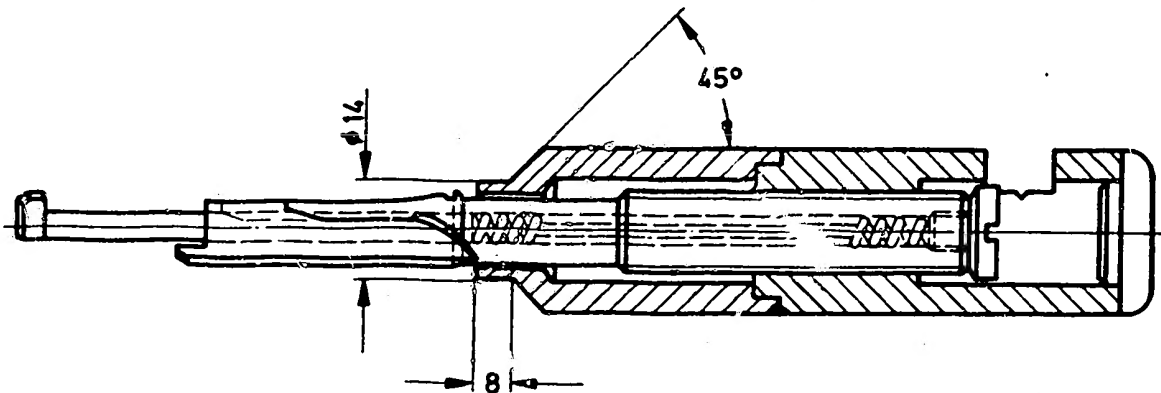

BOSCH

Geschäftsbereich KM, Kundendienst, Kfz-Ausrüstung
© by Robert Bosch GmbH, D-7 Stuttgart 1, Postfach 50 Printed in the Federal Republic of Germany.
Imprimé en République Fédérale d'Allemagne par Robert Bosch GmbH.

N2

Technical Bulletin

PE(S) .. MW .., 0 413 ..



After-sales Service

Technical Bulletin

Only for use within the Bosch organization. Not to be communicated to any third party.

TAPPET HOLDER KDEP 1068
for PE(S) 8 MW.. fuel-injection pumps

VDT-I-413/1001 En
9.1981

Modification to the tappet holder KDEP 1068

The tappet holders for fuel-injection pumps of type PE(S) 8 MW.. of series S 1000 with camshaft with back-kicking prevention have to be modified on the guide surface (see drawing).

Please note:

Since we are concerned here with an aged part, the modification work must be carried out on a grinding machine.
In future new tappet holders KDEP 1068 will be delivered with this modification already incorporated.

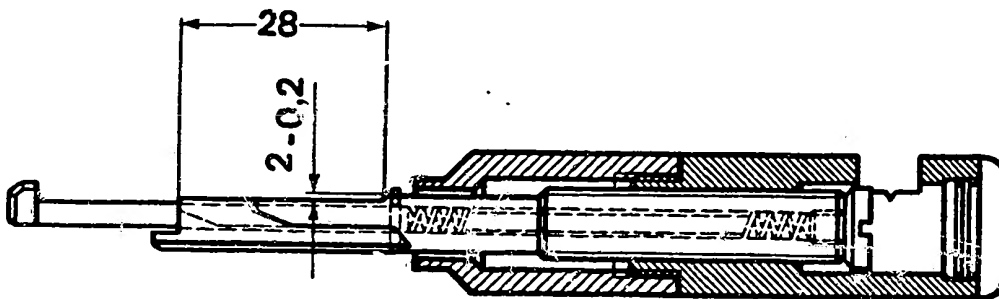

BOSCH

Geschäftsbereich KH, Kundendienst, Kfz-Ausrüstung.
© by Robert Bosch GmbH, D-7 5461 Part 1, Postfach 50. Printed in the Federal Republic of Germany.
Imprimé en République Fédérale d'Allemagne par Robert Bosch GmbH.

N3

Technical Bulletin

PE(S) .. MW .., 0 413 ..



TABLE OF CONTENTS

<u>Section</u>	<u>Coordinates</u>
Structure of microfiche	A 1
1. Special features	A 2
2. Test specifications.....	A 2
3. General information.....	A 11
4. Tools, fixtures, lubricants.....	A 13
5. Exploded views.....	A 18
6. Clamping the injection pump.....	B 1
7. Dismantling the injection pump	B 3
8. Cleaning the components	C 4
9. Checking the components	C 5
10. Repairing the pump housing	C 16
11. Assembling the barrel-and-valve assembly.....	C 23
12. Replacing the camshaft bearing at the drive end	D 2
13. Assembling the injection pump	D 6



Table of contents

Section

Coordinates

Technical Bulletins

N 1

© 1985 Robert Bosch GmbH
Automotive Equipment - After-Sales Service
Department for Technical Publications KH/VDT
Postfach 50, D-7000 Stuttgart 1.

Published by: After-Sales Service Department for Training
and Technology (KH/VSK). Press date: 4.1985.
Please direct questions and comments concerning the
contents to our authorized representative in your country.

This publication is intended only for the Bosch
After-Sales Service Organization, and may not be passed
on to third parties without our consent.

Microfilmed in the Federal Republic of Germany.
Microphotographié en République Fédérale d'Allemagne.

N24

Table of contents/Impressum

PE(S) .. MW .., 0 413 ..

